

THE HALLICRAFTERS CO.

MODELS T-54, 505

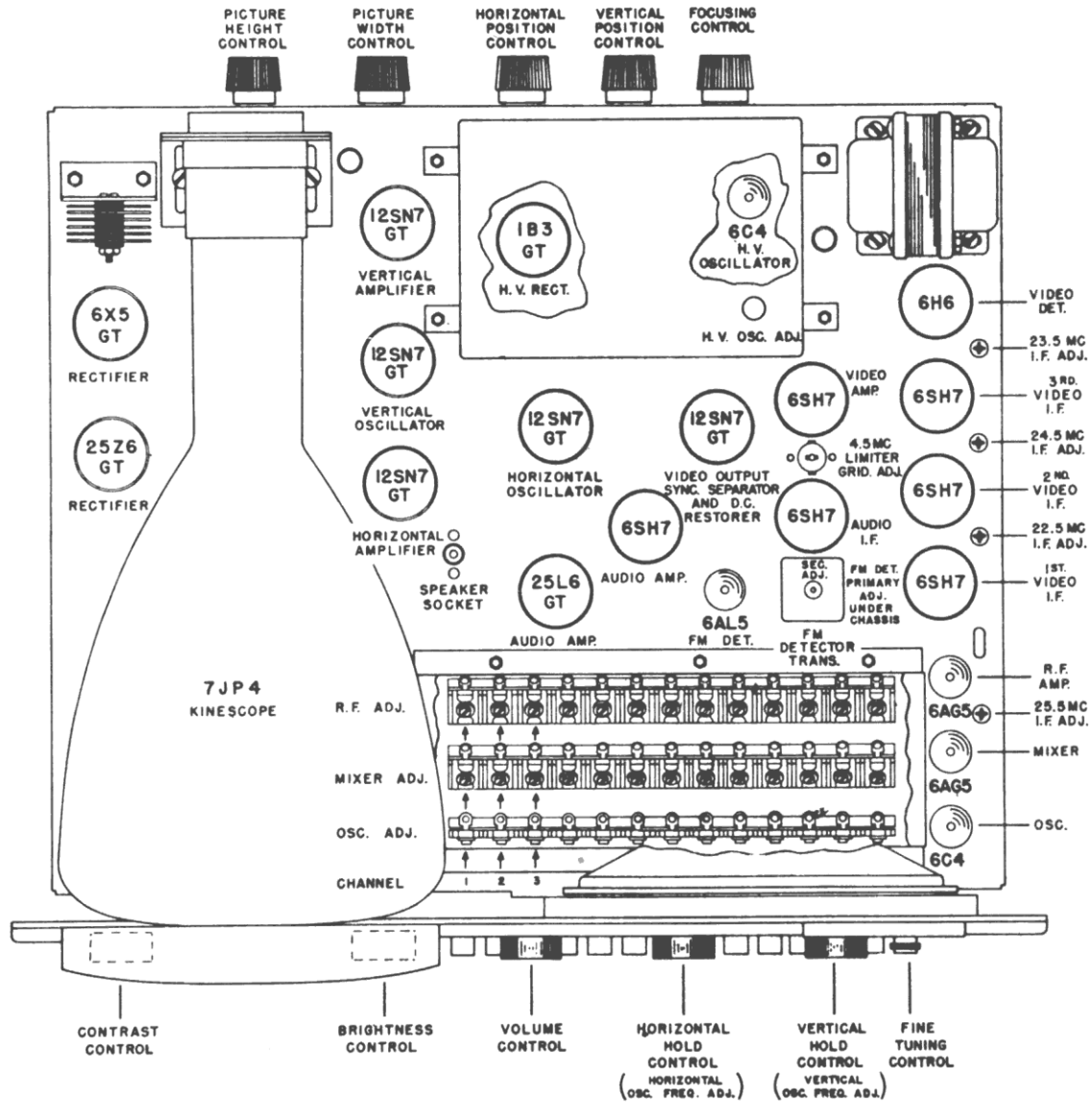

Model T-54

ALIGNMENT INSTRUCTIONS

1. Remove control knobs and panel. The control knobs pull straight off the shaft. The panel is fastened to the cabinet with two panel screws accessible from the outside and two screws accessible from the inside of the cabinet. Since the speaker is fastened to the front panel, its plug must be disconnected from the chassis receptacle. Leave the rubber escutcheon on the kinescope tube for protection.

2. Remove cabinet interlock (receptacle) from cabinet. This is held on with two machine screws.

3. Release the chassis from the cabinet by removing the four rubber feet at the bottom of the cabinet and pull the chassis from the cabinet.

4. Remove the cover over the alignment adjustments just behind the channel pushbuttons and the receiver is ready for alignment.

Model 505

1. Remove the control knobs. They will pull straight off the shaft.

2. Remove the back cover. The line cord and half of the interlock are attached to the back and are removed with the back.
3. Detach the remaining half of the interlock fastened to the cabinet with two wood screws.
4. Release the chassis by removing four mounting screws and pull the chassis clear of the cabinet. Caution: The rubber escutcheon on the kinescope tube should be left on the tube for added protection.
5. Remove the cover over the alignment adjustments just behind the channel pushbuttons and the receiver is ready for alignment.

ALIGNMENT PROCEDURE

Note - Use terminated signal generators only and the shortest possible leads to connect to the receiver circuits.

FM SOUND CHANNEL

1. Connect signal generator between grid of 6SH7 VIDEO AMP. tube (pin #4) and chassis ground.
2. Connect an electronic voltmeter between pin 5 of the 6AL5 FM DET. tube and chassis ground.
3. With signal generator (unmodulated) set at 4.5 MC, set the 4.5 MC LIMITER GRID ADJ. and FM DET. PRIMARY ADJ. for maximum d-c voltage. Adjust the limiter grid coil before adjusting the FM detector primary.
4. Connect electronic voltmeter across 1000 mmf condenser at output of FM detector and adjust SEC. ADJ. of FM DETECTOR TRANS. for the null.
5. Vary the frequency of the signal generator either side of 4.5 MC and touch up the FM DET. PRIMARY ADJ. for equal peaks.

VIDEO I.F. ALIGNMENT

1. Connect the electronic voltmeter across the 0.05 mfd condenser in the automatic gain control (A.G.C.) filter circuit of the video amplifier.
2. Connect signal generator to grid of 6SH7 3RD VIDEO I.F. amplifier tube (pin #4), set signal generator at 23.3 MC (no modulation) and adjust 23.3 MC I.F. ADJ. for maximum d-c voltage.
3. Connect signal generator to grid of 6SH7 2ND VIDEO I.F. amplifier tube (pin #4), set signal generator at 24.5 MC (no modulation) and adjust 24.5 MC I.F. ADJ. for maximum d-c voltage.
4. Connect signal generator to grid of 6SH7 1ST VIDEO I.F. amplifier tube (pin #4), set signal generator at 22.5 MC (no modulation) and adjust 22.5 MC I.F. ADJ. for maximum d-c voltage.
5. Connect signal generator to grid of 6AG5 MIXER tube (pin #1), set signal generator at 25.0 MC (no modulation) and adjust 25.0 MC I.F. ADJ. for maximum d-c voltage.

THE HALLICRAFTERS CO.

MODELS T-54, 505

6. Check the video I.F. amplifier response by tuning the signal generator from 23 MC to 26 MC and observing the change in output voltage over this range. A properly adjusted amplifier should provide a relatively constant output voltage which does not fall more than 30% or 3 db below the peak voltage. If the response does not meet this requirement, a slight readjustment of the I.F. coils may be made to obtain the desired response. The normal video I.F. amplifier sensitivity will run approximately 200 microvolts at the generator terminals for one volt as measured by the electronic voltmeter.

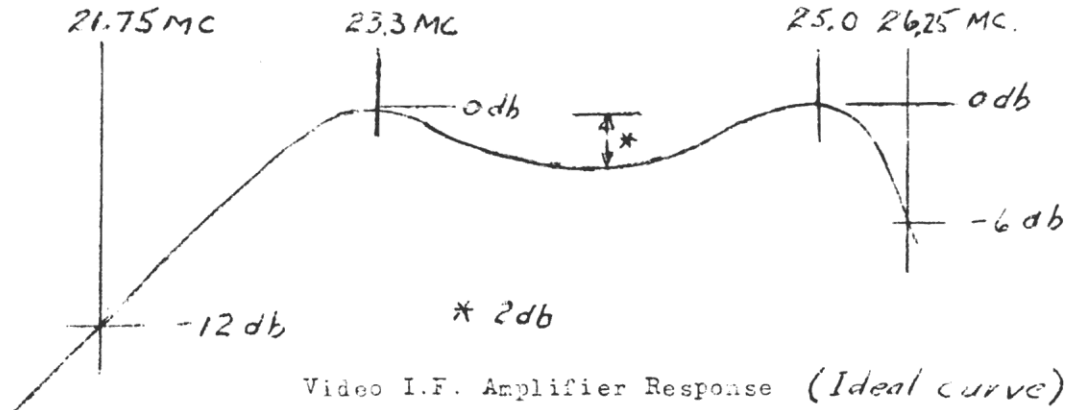

CHANNEL ALIGNMENT

1. Due to the broad response of the video I.F. amplifier, it is necessary to use a 24 MC generator or oscillator (unmodulated) as a BFO oscillator is used in conventional superheterodyne receivers in order to locate the center frequency of the video I.F. amplifier for proper RF alignment. This "BFO" generator or oscillator should be loosely coupled by means of a wire from the generator output placed in close proximity to the 6H6 VIDEO DET. tube.

2. Connect the high frequency signal generator to the receiver's transmission line through two 150-ohm carbon resistors, one connected in each side of the line.

3. Connect the electronic voltmeter between the plate of the 6H6 VIDEO DET. tube (pin #5) and chassis ground.

4. Alignment of the individual channels is carried out as follows. Each channel may be aligned independently without affecting the alignment of the others.

(a) Set FINE TUNING control condenser in the center of its capacity range.

(b) Press the channel button corresponding to the channel number to be aligned.

(c) Set the frequency of HF generator and "BFO" generator per the alignment chart.

(d) Connect a 0.01 mfd condenser between pin #2 of the VIDEO OUTPUT tube and the high side of the VOLUME control and adjust the OSC. ADJUST trimmer corresponding to the channel being aligned for a rough audio beat note using the speaker output as a detector.

(e) Disconnect the 0.01 mfd condenser, shut off the "BFO" signal generator, and adjust MIXER ADJ. and RF ADJ. trimmers for maximum d-c voltage as indicated on the electronic voltmeter. This completes the alignment of any one channel. All other channels are to be treated the same.

ALIGNMENT CHART

CHANNEL NO.	H.F. SIGNAL GENERATOR FREQ.	"BFO" SIGNAL GENERATOR FREQ.
1.	47 MC	24 MC
2.	57 MC	24 MC
3.	63 MC	24 MC
4.	69 MC	24 MC
5.	79 MC	24 MC
6.	85 MC	24 MC
7.	177 MC	24 MC
8.	183 MC	24 MC
9.	189 MC	24 MC
10.	195 MC	24 MC
11.	201 MC	24 MC
12.	207 MC	24 MC
13.	213 MC	24 MC

HIGH VOLTAGE OSCILLATOR ADJUSTMENT

1. Connect a 50 megohm resistor string in series with a 0-200 micro-ampere meter across either of the 1000 mmf 6000 V. filter condensers in the high voltage power supply. The resistor string should be made up of resistors of 10 megohms or less to provide a safety factor for voltage breakdown. Connect the meter on the ground side of the string. Before connecting this string and meter the power should be turned off and sufficient time be given the capacitors to reach complete discharge.

2. A meter reading of 100 microamperes (5000 V.) should be obtained under normal conditions. To obtain the 100 microampere (5000 V.) reading, adjust the H.V. OSC. TRIMMER through the adjustment hole in the top of the H.V. power supply case. Note that increasing the trimmer capacity decreases the voltage and vice versa. The brightness control must be set at minimum or full counter-clockwise for this measurement.

CIRCUIT DESCRIPTION -- HALLICRAFTERS T-54 AND 505

INTRODUCTION

The principles underlying the design of a modern television receiver are more complicated than those on which a simple a-m broadcast set is based. Necessarily, therefore, the circuits of television receivers are more complex than those of standard broadcast sets. The material presented here is offered in the hope that it will be of assistance to the servicemen who may have to repair either of the television receivers described. Of course, this information cannot even approach the general coverage of a text on television, and so it has been assumed in the writing that the reader is familiar with television principles and the more commonly used circuits. Therefore, only the unusual features of these sets are described in any detail; while those characteristics which are commonly found are mentioned only to the extent necessary to preserve the continuity of the description.

The only difference between the T-54 and 505 receivers is in the cabinets used. The former has a metal cabinet, while the latter uses a wooden one.

BLOCK DIAGRAM

The block diagram is a functional breakdown of the receiver circuits, giving a bird's-eye view of their relationships to one another. (Since the chassis used in the two receivers are identical, we shall use the singular -- receiver -- in the remainder of this description, even though both are meant.) The following circuit description is based on this breakdown. In reading it, you should refer to the partial schematics and the associated chassis layouts, showing the waveforms to be observed at various points in the circuit. For most of these waveforms an oscilloscope having an extended high-frequency response (up to, say, 2.5 mc) is required. However, such a scope is not necessary to observe the response curves found in alignment.

FRONT END

The basic characteristics of the front end are conventional. It includes three stages, an r-f amplifier, a converter, and a local oscillator, performing the usual functions associated with each. However, there are several unusual features.

Balanced Input

This receiver is intended to be fed from a balanced 300-ohm source. In order to present a balanced 300-ohm load to the transmission line coming down from the antenna, a combination of grid and cathode input to the r-f amplifier is used. This is shown in Fig. 1. L32 is a balancing coil; its center tap is grounded to r. f. by C3. A direct ground to the chassis cannot be used at this point because one side of the a-c power line is connected to the chassis, and since the antenna lead-in may not be heavily insulated, a direct connection at this point would constitute a potential shock hazard. C1 and C2 perform the same function as C3 in reducing shock hazard, and in addition function as d-c blocking capacitors. R1 and R3 are each 150 ohms, and, since R3 is directly

MODELS T-54, 505

THE HALLICRAFTERS CO.

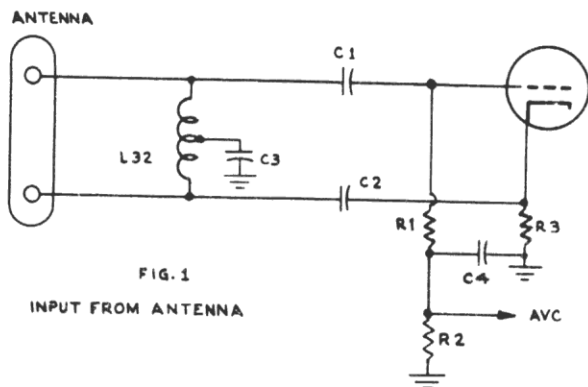

FIG. 1

INPUT FROM ANTENNA

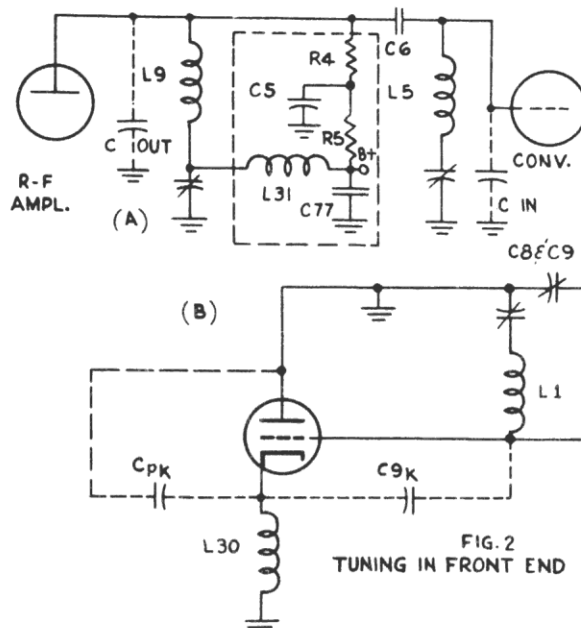

FIG. 2

TUNING IN FRONT END

grounded and R1 is grounded to r. f. through C4, they place a 300-ohm load, balanced to ground, across the antenna input. Since, further, a signal applied to the grid of a tube has the same effect as a similar signal 180° out of phase applied to the cathode, the push-pull signals from the antenna reinforce one another in the input to the r-f amplifier. The output from this stage (not shown in Fig. 1) is conventional in that it is single-ended, that is, not balanced to ground. The plate tuning is, however, somewhat unusual.

Tuning

This receiver covers all 13 television channels allocated to commercial service by the FCC. Mechanically, the particular channel desired is selected by depressing the appropriate pushbutton on the front panel. Fine tuning is accomplished by means of a small knob alongside of and resembling the pushbuttons. When a pushbutton is depressed, it selects the appropriate components to tune the three resonant circuits in the front end. For all 13 channels the "appropriate components" consist of capacitors, and in the case of the six low-frequency channels, coils are added to the circuits as well. Although it is hardly unusual to use pushbuttons to select tuned circuits in the standard broadcast band, it is anything but usual at the frequencies of television broadcasting, and the tuned circuits used reflect this condition.

The tuned circuits employed in the front end of this receiver are illustrated in Figs. 2 (A) and (B). Fig. 2 (A) shows the tuning of the plate of the r-f amplifier and the grid of the converter; since they are so closely connected together in actuality, they are shown together here. In drawing this, R108 and R6 (the converter grid return) and some inductors, capacitors, and resistors have been omitted for the sake of simplicity. R108 is simply used as a coil form for L9 and, because of its high resistance, has negligible electrical effect. The other omitted resistors, which are mechanically part of the pushbutton assembly, are used similarly as coil forms. However, their resistances are relatively low, and so they also serve the electrical purpose of loading their associated coils. This is necessary because these coils are used only for the low-frequency channels, and it is important that they have broad band-pass characteristics. If the components enclosed in the dashed lines are temporarily ignored, it will be observed that the circuits on either side of C6 are the same. C_{out} is the output capacitance of the r-f amplifier,

THE HALLICRAFTERS CO.

MODELS T-54, 505

and C_{in} is the input capacitance of the converter. The unlabeled variable capacitors are those selected by the pushbutton switches; on the six low-frequency channels there are also inductors in series with them. L31 and C77 form a decoupling filter; R5 and C5 perform the same function (the screen of the r-f amplifier is connected to their junction), and R4 is a camping resistor.

The oscillator, which is shown in Fig. 2 (B), is a modified Colpitts. The diagram has been drawn in such a way as to emphasize this, and the d-c grid and plate connections have been omitted for the sake of simplicity. C_{pk} is the plate-cathode capacitance and C_{gk} is the grid cathode capacitance. The unlabeled variable capacitor which is part of the tank represents C91 and the tuning capacitor chosen by the push-button switch assembly for the channel in use. As in the case of the r-f and converter tuning, inductors are added in series with the tuning capacitor on the low-frequency channels. These coils are also wound on resistors, but, because this is an oscillator and as such should not have broad-band characteristics, 1-megohm resistors are used in all cases. C8 is a fixed capacitor in series with C9, which is the fine tuning control. As is customary in television receivers, the oscillator is tuned to a frequency higher than the incoming signal.

The 39 (13 channels times 3 tuned circuits) tuning capacitors are mounted in 3 rows above the push-button switches. Each is a compression-type trimmer; and, since only one set of 3 is in the circuit at a time, the alignment of each channel is independent of the others.

Avc voltage is applied to the r-f amplifier at the low end of grid resistor R1. This effectively places the avc voltage in series with r-f grid voltage.

In addition to the extra inductors added by the switch mechanism on the six low-frequency channels, additional inter-stage coupling capacitors are introduced when reception of these channels is desired. Their additional capacitance is necessitated by the relatively low frequencies of channels one to six. Another point that should be observed is the use of capacitors C83 and C93. Because of the inherent design of the tuning assembly, some frequencies, at which the oscillator must work, tend to become absorbed unless these capacitors are used. These additional capacitors sufficiently detune these absorption circuits to permit proper operation of the oscillator.

(Capacitors C83 and C93 are not illustrated in Fig. 2 (A) in order to simplify this figure as much as possible.)

VIDEO SECTION

Included in the video section are the main (or video) i-f amplifier, the video detector, and two stages of video-frequency (v-f) amplification.

Main I-F Amplifier

Contrary to usual practice, a single channel is used in this receiver to amplify both video and sound i-f signals. (In addition, there is a single stage of audio i-f amplification which is discussed further on.) Ordinarily, separate i-f amplifiers are used for video and sound to prevent interaction between the two signals. In this receiver, however, this interaction is put to use; the two carriers beat together in the video detector, giving a 4.5 mc signal. This signal may be considered as a second (sound) i.f.; it is frequency modulated just as the first sound i. f. is, and may therefore be demodulated by conven-

tional techniques. A television receiver sound system of this type is known as an intercarrier sound system, since it depends for its action upon intermodulation of the sound and video carriers.

There are three stages of main i-f amplification, and four associated tuned circuits. Each of these is single-tuned. The first three are arranged identically. For example, L14, the plate load of the converter, is a variable inductor having a movable core. It is tuned by the output capacitance of the converter and the input capacitance of the following stage, the first i-f amplifier. In order to lower its Q in the interest of attaining a broad pass band in the i-f amplifier, it is loaded by the 27,000-ohm grid resistor of the following stage. L15, the plate load of the first i-f amplifier, and L16, the plate load of the second i-f amplifier, are tuned and loaded in the same manner. L27, the plate load of the third i-f amplifier is simply an untuned r-f choke. However, the signal from this plate is fed to the cathode of the diode detector, and in this cathode is a variable inductor, L17. This inductor is of the same design as L14, L15, and L16, and is similarly tuned. It is loaded by the input resistance of the diode. In addition to loading, stagger tuning of the four coils is used to broaden the response of the i-f amplifier. They are tuned as follows: L14 - 25 mc, L15 - 22.5 mc, L16 - 24.5 mc, and L17 - 23.3 mc. The band-pass characteristics obtained by this stagger tuning and loading are illustrated by tracings of oscillograms included with the alignment instructions

It will be observed from these oscillograms that the pass band of the receiver is sufficiently narrow to exclude adjacent-channel interference without the need of traps. This is possible because with a 7-inch picture tube adequate definition is obtained even with a relatively restricted high-frequency video response. In addition, since the 26.25 mc picture i-f carrier signal and the 21.75 mc sound i-f carrier signal appear at or near the base line of the response curve (see Fig. 12 in alignment section), they will not produce a very strong beat. Therefore, one 4.5-mc trap (C58 and L29) is sufficient to prevent this beat signal from interfering with proper signal reproduction. On the other hand, a sufficiently strong beat signal is obtained in this manner so that, after a single stage of audio i-f amplification, it will give proper operation of the ratio detector.

Avc voltages are applied to the first and second i-f amplifiers, but not to the third. In this amplifier a small bias is produced by signal rectification in the grid circuit. Because of this effect, the negative grid bias here rises from about 0.3 volt in the absence of a received signal (noise input) to about 0.6 volt when a weak but usable signal is received. A high degree of interstage decoupling is found along the avc bus, and the same is true of the plate and screen supplied of the i-f amplifiers.

Detector

A single diode is used in a conventional rectifier circuit as the video detector. It produces a video frequency (v-f) signal of such polarity that the sync pulses are negative-going. Its d-c output is used to provide an avc signal for the r-f amplifier and the first and second video amplifiers. A third function of the detector is intermodulation of the picture and sound i-f carrier signals. As explained previously, this beat signal is demodulated to provide the audio output of the receiver.

Video Amplifier

The v-f output of the detector is coupled through a high-frequency compensating circuit employing both shunt and series-peaking coils to the grid of the first video amplifier. This stage employs a high-trans-conductance pentode, and gives a gain of 20-25 times. Since the contrast control is a variable resistor in the cathode circuit of this stage, the gain can be given only as an approximation. Variation of the contrast control varies the bias developed across it, thereby controlling the gain of the stage.

The output of the first video amplifier is fed through a high-frequency compensating circuit, to the grid of the second video amplifier. This amplifier is one section of a dual triode connected as a cathode follower. Its output is applied to the cathode of the picture tube and to the grid of the second section of the dual triode. (This section functions as a d-c restorer and sync separator.) The purpose of the cathode follower is to present a constant, high impedance to the compensating network in the plate circuit of the first video amplifier. Without it, this network would be loaded by the variable and relatively low impedance presented by the picture tube cathode and combined d-c restorer and sync separator. The gain of the second video amplifier (cathode follower) is approximately 0.65 times.

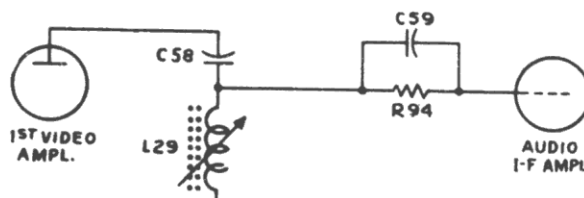

FIG. 3
COUPLING FROM 1ST VIDEO AMPLIFIER TO
AUDIO I-F AMPLIFIER.

A second output from the first video amplifier is obtained directly from the plate, rather than through the compensating network. This is the 4.5-mc beat, which goes to the audio section. The method of coupling is illustrated in Fig. 3. C58 and L29 are series tuned, so that they present a near short to the 4.5-mc beat at this point. This prevents the beat signal from continuing further to the picture tube, where it would interfere with proper reproduction of the signal. Also by virtue of and series tuning, a large 4.5-mc signal appears across the individual components of the series-tuned circuit. The signal appearing across the inductor provides the input to the audio i-f amplifier. The first video amplifier has still a third function, that of a noise limiter. Since the output of the detector is such that the sync pulses are negative-going, any high-amplitude noise pulses will drive the grid of the first video amplifier very negative. This will cut the amplifier off, as a sharp-cutoff pentode is used here. Therefore, the noise will not pass through to the plate circuit, and so the effective signal-to-noise ratio is improved.

SYNC SEPARATOR AND D-C RESTORER

Usually the d-c restorer is treated as part of the video amplifier, and the sync separator as part of the sweep system. However, in this receiver a single triode performs these two functions, and so it would be an artificial and ill-advised procedure to consider them separately. The circuit is shown

in Fig. 4. At the grid the sync pulses are positive-going, since the polarity of the output of the detector is reversed in the first video amplifier, but not in the second. The cathode resistor and capacitor are both very large; R66 is 33,000 ohms and C50 is 5 microfarads. This combination causes the stage to act very much like an infinite-impedance detector. The peaks (sync pulses) of the grid signal are just high enough to cause conduction through that tube; the charge developed on the cathode capacitor cannot leak off quickly through the parallel resistor, so that tube is biased beyond cutoff except at the peak of each cycle of input. Since this bias corresponds to a value slightly below the input peaks, it corresponds to the black level of the video signal, which is slightly below the sync pulses. Therefore, the cathode voltage of this tube is applied to the grid of the picture tube, to set the black level of the scene visible on its screen.

Since the tube conducts only on the peaks of the input signal, the plate current flows in pulses, causing pulses of voltage to appear across the load resistor, R93. Since, further, these input peaks are the sync pulses, the voltage pulses across R93 will be the same sync pulses, but inverted so as to be negative-going. Thus, the sync pulses are passed into the plate circuit of the tube; but, because the tube is cut off at the video signal level, video signals do not come through. In this manner the tube acts as a sync separator, and the plate signal is fed to the sweep circuits. Since negative-going sync pulses are needed to synchronize the sweep multivibrators, the plate pulses are of the correct polarity.

SWEEP CIRCUITS

The function of the sweep circuits is to produce deflection voltages that will cause the electron beam in the picture tube to sweep out a raster in

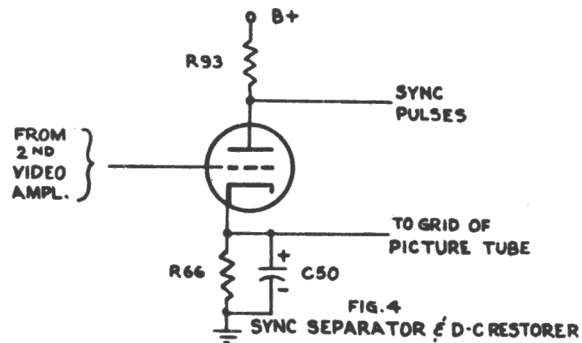

synchronism with that in the camera tube where the program originates. The horizontal and vertical sweep circuits are the same in all major respects, but there are certain differences in detail which stem from the differences in operating frequencies.

Horizontal and Vertical Sync Separation

Since both the horizontal and vertical sync pulses appear in the output of the sync separator tube, some means must be provided to distinguish between them before they are applied to the sweep oscillators. The distinction is made on the basis of sync pulse width. The horizontal sync pulses are narrow, while the vertical sync pulses are wide. The networks which separate the two types of sync signals are shown in Fig. 5. Pulses fed through the d-c blocking capacitor C22 to the lower network, charge capacitors C14 and C15 through resistors R17 and R16. Between pulses the charge leaks off. Since the horizon-

tal pulses are narrow, the charge leaks off almost completely between pulses. The resultant voltage applied to the grid of the vertical oscillator is negligible. However, when a wide vertical pulse is applied, a voltage sufficient to trigger the vertical oscillator builds up. Part of the charge leaks off in the serration intervals, but they are so narrow that their effect on the operation of the network is very slight. After the vertical pulse passes, the charge leaks off. Between vertical pulses, the voltage drops back to the negligible value produced by the horizontal pulses. Resistor R15 performs a voltage-dividing function, as well as providing a d-c path to ground for the grid and to discharge C14 and C15. The purpose of this voltage-dividing is to produce a sync signal of the proper amplitude for the vertical oscillator.

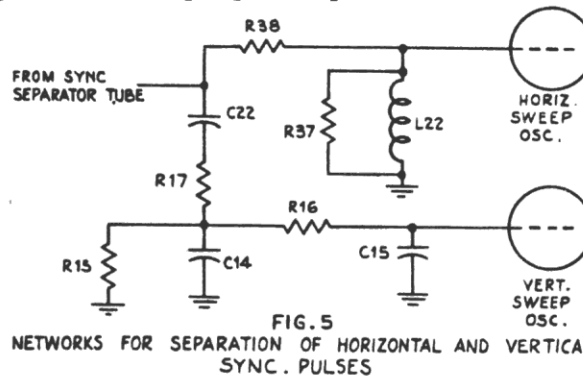

When sync pulses are applied to the upper network, the sudden application of voltage causes a corresponding sudden flow of current. This sudden flow of current through the inductor L22 produces a pulse of voltage across it. At the end of a pulse, when the current through the network is cut off, another pulse, of opposite polarity, is produced across L22. Since the incoming sync pulses are negative-going, the pulse across L22 which is produced by the leading edge of the incoming pulse is also negative-going. The sweep oscillator used here requires negative-going pulses for synchronization, so the leading-edge pulses will trigger it, but the trailing-edge pulses have negligible effect. This behavior is used to maintain synchronization during the vertical sync period, because the spacing of the equalizing pulses and the serrations in the vertical sync pulse is the same as the spacing of the horizontal sync pulses. Although the equalizing pulses and the serrations in the vertical pulse have different widths from the horizontal pulses, the negative-going pulses that they produce across L22 are spaced the same. (The positive-going pulses are spaced differently, but that is of no significance here.) Thus, the desired maintenance of synchronization is obtained. Resistor R37 performs the same function of reducing sync pulse amplitude as R15 in the lower network.

Sweep Oscillators

The sweep oscillators are of the type known as the Potter sweep circuit; this circuit is named for its inventor. This circuit is basically a cathode-coupled multivibrator, used as an electronic switch. During the forward trace time, the switch is open, and a capacitor is charged through a resistor. During the retrace, the switch closes, and discharges the capacitor through a resistance much smaller than the resistor through which it is charged. Thus a slow rise and rapid fall of voltage are produced across the capacitor; this is the required saw-tooth wave. The natural frequency of the sweep circuit is adjusted so that in the absence of sync, its period is slightly longer than that required. When sync pulses are applied, they initiate the retrace, so that it occurs just before it would occur in their absence. In this manner, synchronism is maintained between camera and picture tube sweeps.

The vertical sweep amplitude (that is, the height of the picture) is controlled by means of a potentiometer, R23, connected across the output of the sweep oscillator. The position of the variable arm of the potentiometer determines the amplitude of the sweep signal fed to the sweep amplifier and thus to the picture tube. This arrangement makes the "HEIGHT" and "VERTICAL" (hold) controls independent to each other, since the position of the arm reflects no significant effect into the sweep circuit. The "VERTICAL" control adjusts the natural frequency of the vertical sweep oscillator so that optimum sync action takes place.)

Since the horizontal sweep oscillator runs at a much higher frequency than the vertical oscillator (262.5 times as fast), a different method of sweep-amplitude control is required. If the same method were used, the distributed capacitance in the potentiometer, in conjunction with its resistance would distort the sweep waveform. In this case, then, the sweep amplitude is controlled by varying the charging voltage available to the capacitor across which the sweep saw-tooth is generated. This causes a slight dependence of the "HORIZONTAL" (hold) control setting upon the setting of the "WIDTH" control.

Sweep Amplifiers

The output of the vertical sweep oscillator is fed through the "HEIGHT" control to one section of a dual triode, functioning as a conventional RC-coupled amplifier. The entire output of this section is applied to one of the vertical deflection plates of the picture tube. In addition, part is tapped off a resistive voltage divider and applied to the second section of the tube. The loss in the voltage divider is just equal to the gain in the second section, so its output is equal to that of the first section, but of opposite polarity. (In other words, the second section, in connection with the voltage divider, forms a unity-gain phase inverter.) The output of the second section is fed to the vertical deflection plate opposite to that fed by the first section. The two sections have a common unbypassed cathode bias resistor. This tends to equalize the outputs of the two sections, since any inequality in signal causes a signal to appear across this resistor. (If the signals are equal, they cancel out in this resistor, since they are of opposite phase.) The phase of such a cathode signal is automatically of the correct phase to reinforce the grid signal of the section producing the lower output. This effect increases the output of the weaker section.

A similar, but not identical, amplifier-phase inverter combination is used to deliver the horizontal sweep signal to the picture tube. In this case there is no variable resistor (sweep amplitude control) connected to the input grid. It is, therefore, possible to obtain the bias by the use of the grid-current voltage drop across large resistors, R29 and R30, and this eliminates the need for a cathode bias resistor. The voltage divider between the plate of the first section and the grid of the second section is capacitive. One section of the divider is the coupling capacitor, C27, which is only 6 mmf. The other section of the divider is the input capacitance of the tube. Because of the Miller effect, this capacitance is of the order of 40 to 50 mmf, giving the proper division ratio. The input capacitance is shunted by the grid resistor but this is so large as to have a negligible effect on the division ratio and waveform.

PICTURE TUBE

The picture tube is operated with its cathode in the neighborhood of 200 volts above ground. This permits the necessary direct connection to its grid from the d-c restorer, since this d-c restorer operates from the common low-voltage power supply. It also permits connection of the picture tube heater to the heaters of the other tubes in the receiver.

AUDIO SECTION

The audio section is quite conventional. As shown in Fig. 3, the 4.5-mc intercarrier beat signal is fed from the plate of the first video amplifier to the grid of the audio i-f (or beat-frequency) amplifier. Grid bias is developed by grid rectification of the signal, in conjunction with C59 and R94. This rectifying action loads the tuned inductor L29, giving the tuned circuit the bandwidth necessary to handle an f-m signal without distortion.

The audio i-f amplifier feeds a conventional ratio detector having a bandwidth of approximately 200 kc between peaks. The output of the ratio detector is fed through the volume control to the first a-f amplifier, a pentode. The case of the volume control is grounded through a capacitor to minimize noise pickup; being a panel control, it cannot be grounded directly because of the shock hazard. The output of the first a-f amplifier is RC-coupled to the power amplifier, a beam-power tube. The speaker is an oval p-m dynamic, with a 7" x 4 1/2" cone.

The ratio detector tube must not be removed from its socket when the power is on, or the resistor in parallel with its heater will blow out. This resistor is used to lower the heater current through the tube, thereby reducing hum.

POWER SUPPLIES

There are three major power supply sections, the heater supply, the low-voltage supply, and the high-voltage supply. The heater supply is simplicity itself, consisting of the heaters and a few appropriate resistors in a series-parallel combination across the power line. There are also several r-f bypass capacitors and two r-f chokes in the heater string.

Low-Voltage Supply

Two vacuum diodes and a selenium rectifier are used in the low-voltage supply. One of the tubes is a dual diode, one section of which is used in a negative-voltage supply. The cathodes of the sweep amplifiers are returned to this supply rather than to ground, thus increasing their effective plate-supply voltages. The second section of the dual diode is used with the other tube and the selenium rectifier in a positive voltage-tripling supply.

This supply is tapped at three points, giving 120, 230, and 390 volts. The negative supply delivers 125 volts. Both supplies are transformerless, and one side of the power line is grounded to the chassis. For this reason, numerous precautions, such as insulation of the hold-down brackets from the chassis, have been taken to protect persons using this receiver.

MODELS T-54, 505

THE HALLICRAFTERS CO.

HIGH-VOLTAGE SUPPLY

The high-voltage supply is of the r-f type. It incorporates a power oscillator operating in the range of 200 kc, and supplying both heater and plate power to the high-voltage rectifier at this frequency. The rectifier is a vacuum diode specially designed for this service. A supply of this kind has several advantages over one designed to operate directly from the a-c power line. The transformer has an air core, making it much lighter, and more compact, and the insulation problems of this component are much simpler. Also, the required filter capacitors are much smaller, saving space and weight, and being less of a source of danger. The danger is less because they store less energy than larger capacitors operating at the same voltage, so that a shock from them is less likely to be lethal. Further, the regulation of such a supply is poorer than that of a 60-cycle supply, so if accidental contact is made with it, the voltage will drop considerably because of the added load.

The oscillator is of the tuned-plate, tickler feedback type. The output voltage of the rectifier can be varied by changing the operating frequency of the oscillator by means of tuning capacitor C32. The correct voltage is obtained by tuning to the low-frequency (high-capacity) side of the point of maximum output. This tuning gives better operation under load than tuning to the high-frequency side. Plate power for the oscillator is supplied from the 230-volt tap on the low-voltage power supply.

The high-voltage power supply is mounted on a sub-chassis, which is completely shielded. This reduces radiation and danger of accidental contact with the high-voltage circuit. Radiation is further reduced by r-f chokes in the low-voltage leads.

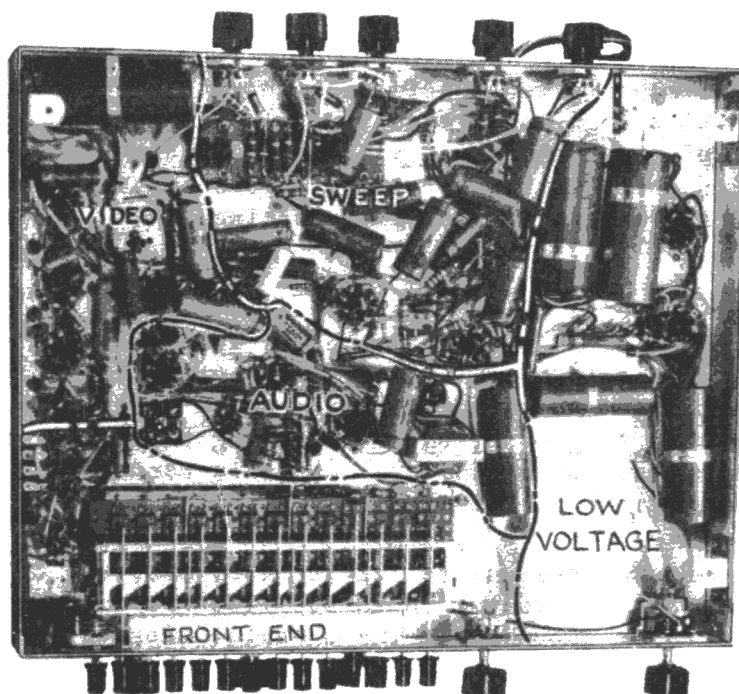
CHASSIS - BOTTOM VIEW

ALIGNMENT PROCEDURE

TEST EQUIPMENT

CATHODE RAY OSCILLOSCOPE - Any good scope will be satisfactory for alignment. However, for observing waveforms at the different test points in the receivers, an oscilloscope with a wide-band vertical amplifier response (about 2.5 mc's) should be used.

SWEEP GENERATOR - The sweep signal generator should cover the following range of center frequencies with the indicated sweep widths:

- 18 - 30 mc with a 10 mc sweep
- 44 - 88 mc with a 10 mc sweep
- 174 - 216 mc with a 10 mc sweep
- 4.5 mc with a 2 mc sweep

The output of the signal generator should be continuously variable with a maximum output of at least 0.1 volt. A horizontal sweep output from the sweep signal generator to the oscilloscope is desirable.

MARKER SIGNAL GENERATOR - This signal generator should cover the following frequency ranges:

- 18 - 30 mc
- 44 - 88 mc
- 174 - 216 mc
- 2 - 6 mc

The output of this signal generator should be continuously variable with a maximum output of at least 0.1 volt.

Any signal generator with an accurate frequency calibration may be used, to obtain the marker required for response patterns.

VACUUM TUBE VOLTMETER - A VTVM with a low dc volt scale of approximately 3 volts and at least a 10-megohm input resistance is desirable. A VTVM with a zero-center movement is useful.

METER AND OSCILLOSCOPE ALIGNMENT

For over-all alignment, the different sections of the receiver should be aligned in the following order:

- 1 - Video I-F
- 2 - Audio I-F
- 3 - Front End

Any one section may be aligned by itself if it is obvious that only that section needs alignment. Before aligning either of the i-f sections, ground the AVC by placing a jumper from the junction of R56 and C54 to ground.

MODELS T-54, 505

THE HALLICRAFTERS CO.

VIDEO I-F - When obtaining the over-all video i-f response pattern (step 4), trouble may arise due to regeneration within the i-f amplifier. This will cause the response pattern to become distorted and unstable. In most cases, regeneration can be eliminated by reducing the coupling between the sweep generator and the receiver by placing a very small capacitance in series with the output lead from the signal generator. This capacitance can be obtained by using a "gimmick" which will approximate 1 to 2 mmf. Very often sufficient coupling will be obtained by merely placing the output lead of the sweep signal generator near the grid of the mixer tube.

The marker signal generator is also loosely coupled to the same point as the signal generator. DO NOT tie the outputs of the two signal generators together. When obtaining markers on the response pattern, it will usually be sufficient to place the output lead of the marker signal generator near the output lead of the sweep generator. Be careful of false responses due to overloading. Always use as low an output as possible.

Step	Sweep Gen.	Marker Gen.	Signal Input	Output	Adjust	Remarks
1	-----	23.3 mc	pin #1 6A65-1	VTVM R56 and R57	L17 for max output on meter	Use minimum input signal
2	-----	24.5 mc	same as 1	same as 1	L16 for max on meter	same as 1
3	-----	22.5 mc	same as 1	same as 1	L15 for max on meter	same as 1
4	-----	25.0 mc	same as 1	same as 1	L14 for max on meter	same as 1
5	-----	23.5 mc with 10 mc sweep	A-21.75 mc B-23.3 mc C- 25.0 mc D-26.25 mc	same as 1	oscillos- cope pin 4 6SH7-6	Touch up slugs to get response shown in Fig 12

AUDIO ALIGNMENT - Set marker signal generator to 4.5 mc. Connect to pin 4 of the 6SH7-6 video amplifier.

- 1- Connect VTVM to pin 4 of 6SH7-4 audio i-f and adjust L29 limiter grid adjustment for maximum indication on meter.
- 2- Connect VTVM to junction of C64 and R99, which is also center tap of secondary of f-m detector and adjust f-m detector primary for maximum indication on meter.
- 3- With VTVM in same position as in step 2, adjust secondary of f-m detector for zero indication. A zero-center VTVM is useful for this operation.
- 4- Place a 50 mmf capacitor between output of marker signal generator and pin 4 of 6SH7-6. Connect sweep generator to pin 4 of 6SH7-6 and set at 4.5 mc with a 2 mc sweep. Connect oscilloscope to junction of R99, C65, and C66. Response pattern obtained should correspond to Fig. 11. If necessary, touch up f-m detector by repeating steps 2 and 3 to secure straight center-slope response and symmetrical peaks.

THE HALLICRAFTERS CO.

MODELS T-54, 505

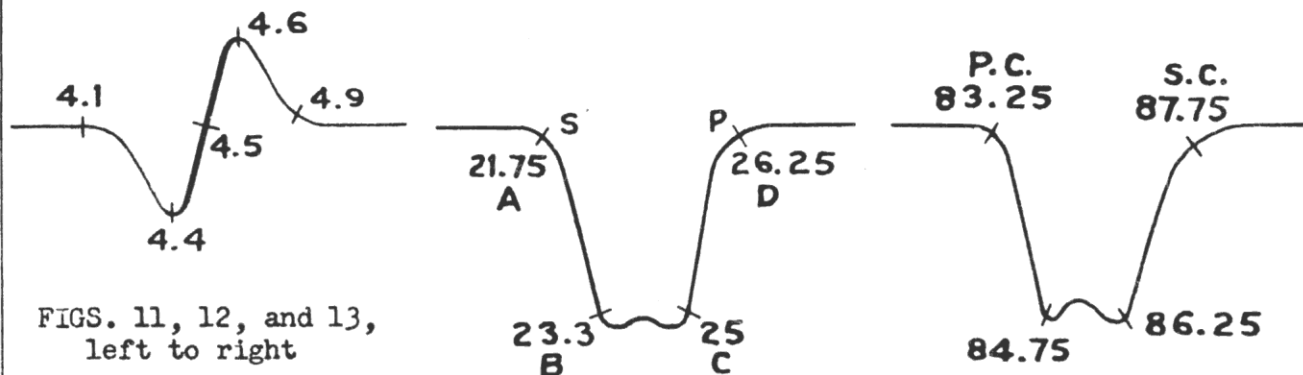

FIGS. 11, 12, and 13, left to right

FRONT END ALIGNMENT - Each channel is aligned in the following manner:

The sweep signal generator is connected to the antenna terminals, and is set at the center frequency of the channel with a 10-mc sweep width. The oscilloscope is connected to the input of the video amplifier (pin number 4 of the 6SN7-6). The marker generator is loosely coupled to the antenna terminals and set in turn to the picture-carrier and sound-carrier frequencies of the particular channel being aligned.

Referring to the typical over-all response shown in Fig. 13, the following adjustments are made for each channel. (The particular adjustments discussed here are for channel 6 but they are similar for all other channels.)

- 1- Set fine tuning controls so that condenser is half meshed.
- 2- Adjust oscillator trimmer (C105C) so that the picture and sound carriers fall on either side of the response curve as shown in Fig. 13. The oscillator adjustment and the markers set for either picture or sound, will apparently move along the curve. Proper adjustment of the oscillator trimmer will result in the positionings of the marker as shown in Fig. 13.
- 3- Adjust the mixer trimmer (C105B) and the r-f trimmer (C105A) so that the peaks of the response curve are as nearly symmetrical as possible, as shown in Fig. 13.

RADIO FREQUENCY RANGES

Channel Number	Channel Freq. MC	Picture Carrier Freq. MC	Sound Carrier Freq. MC	Receiver Osc. Freq.
1	44-50	45.25	49.75	71.5
2	54-60	55.25	59.75	81.5
3	60-66	61.25	65.75	87.5
4	66-72	67.25	71.75	93.5
5	76-82	77.25	81.75	103.5
6	82-88	83.25	87.75	109.5
7	174-180	175.25	179.75	201.5
8	180-186	181.25	185.75	207.5
9	186-192	187.25	191.75	213.5
10	192-198	193.25	197.75	219.5
11	198-204	199.25	203.75	225.5
12	204-210	205.25	209.75	231.5
13	210-216	211.25	215.75	237.5

MODELS T-54, 505

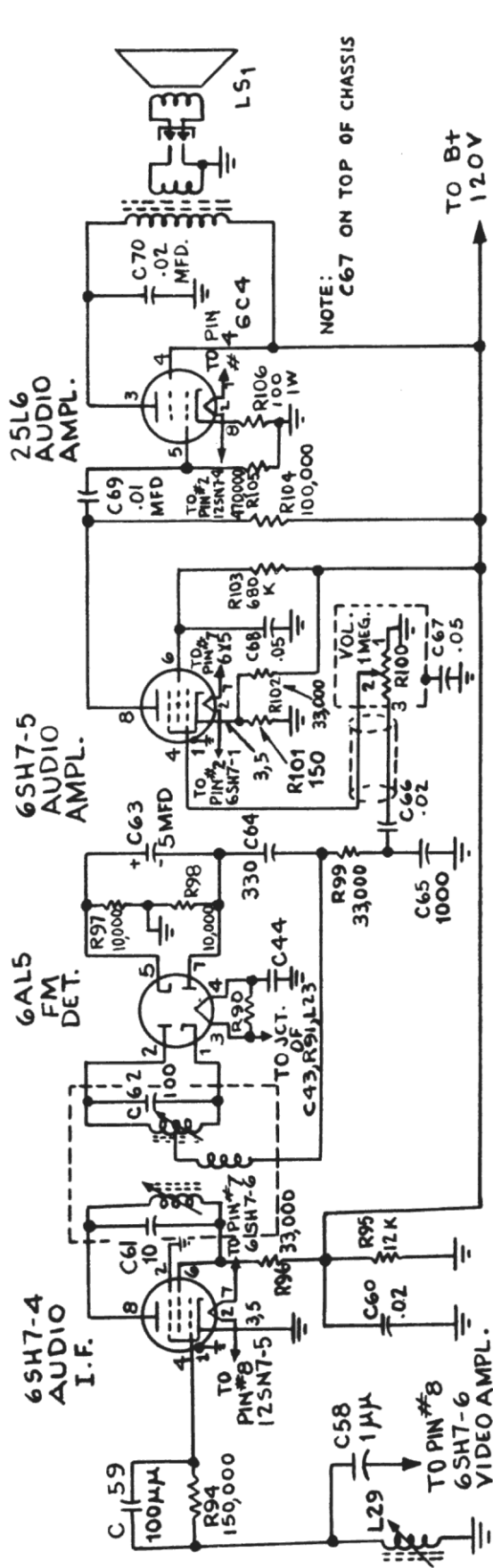

SCHEMATIC (AUDIO SECTION)

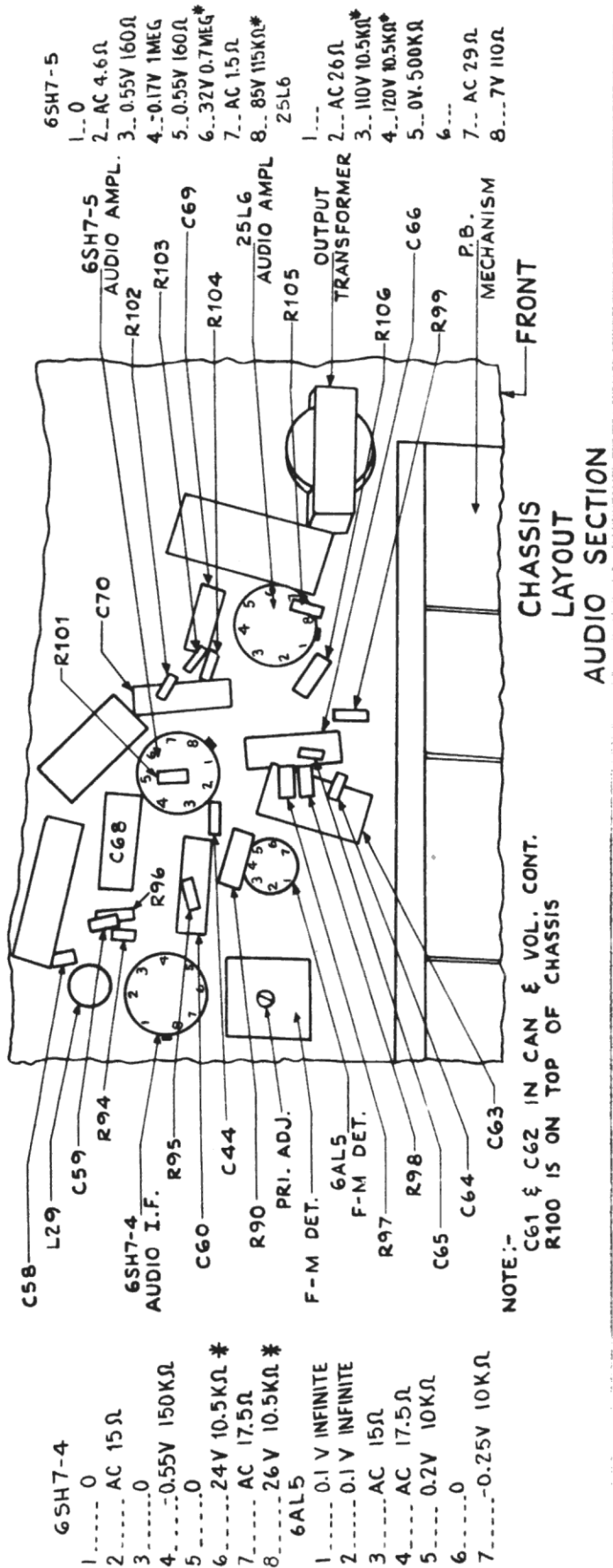

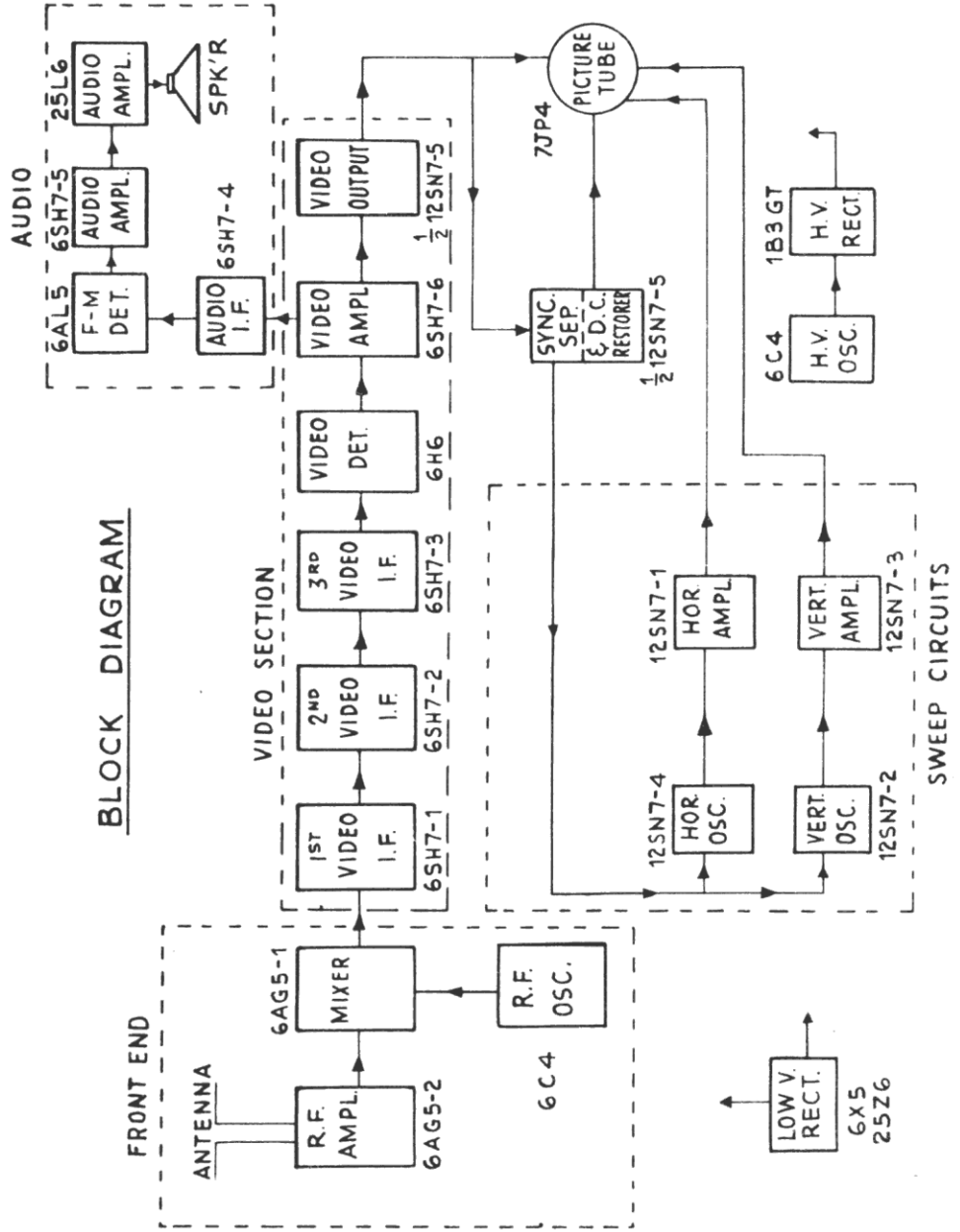
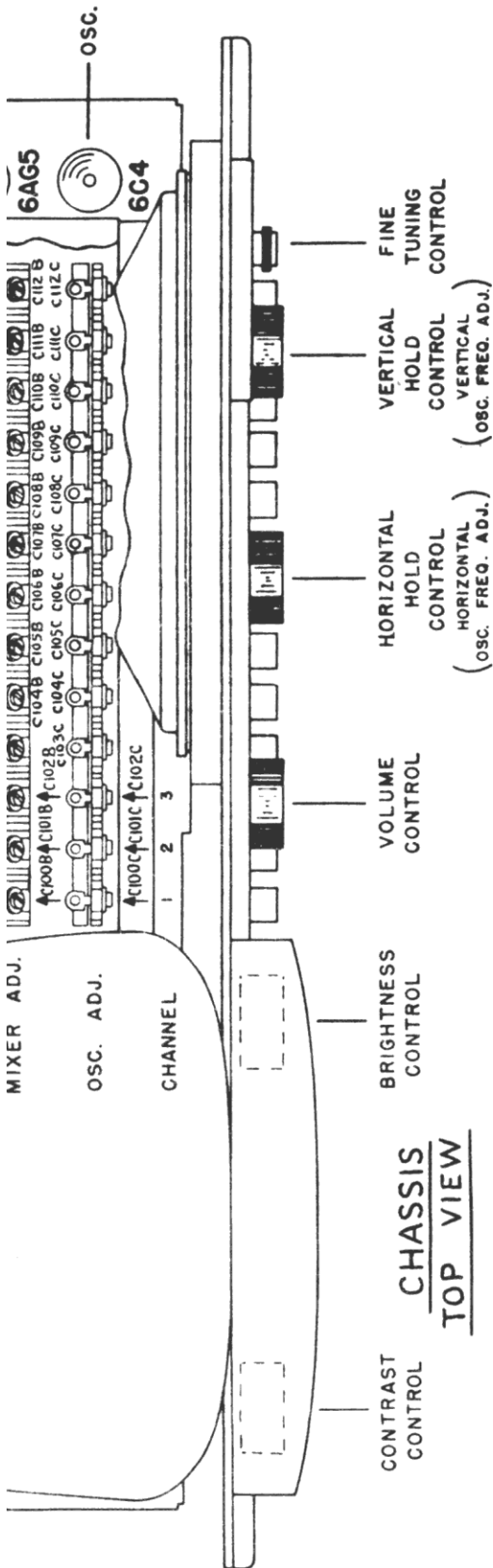

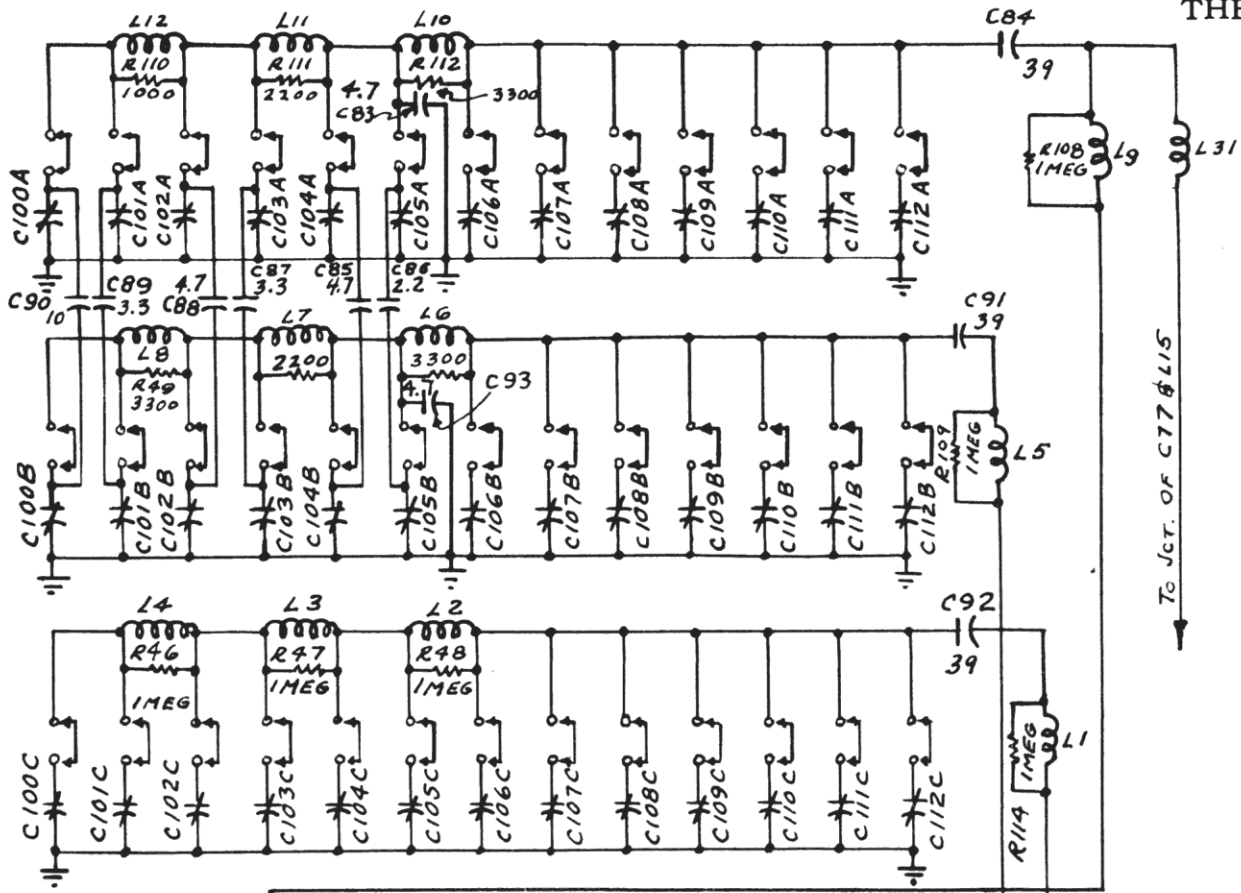

SCHEMATIC - FRONT END

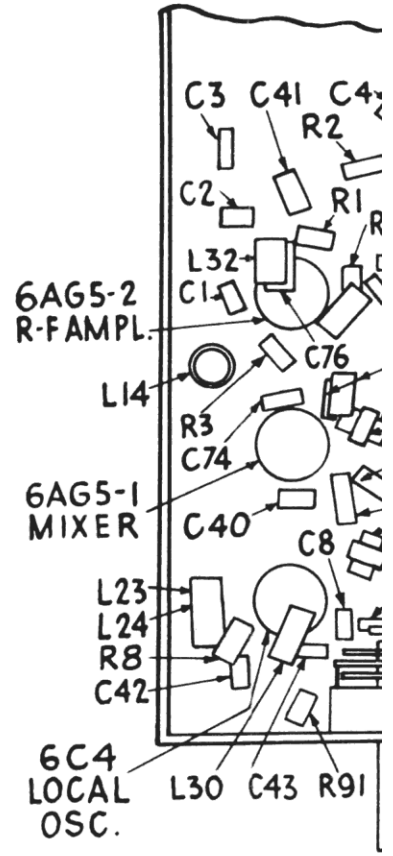

31

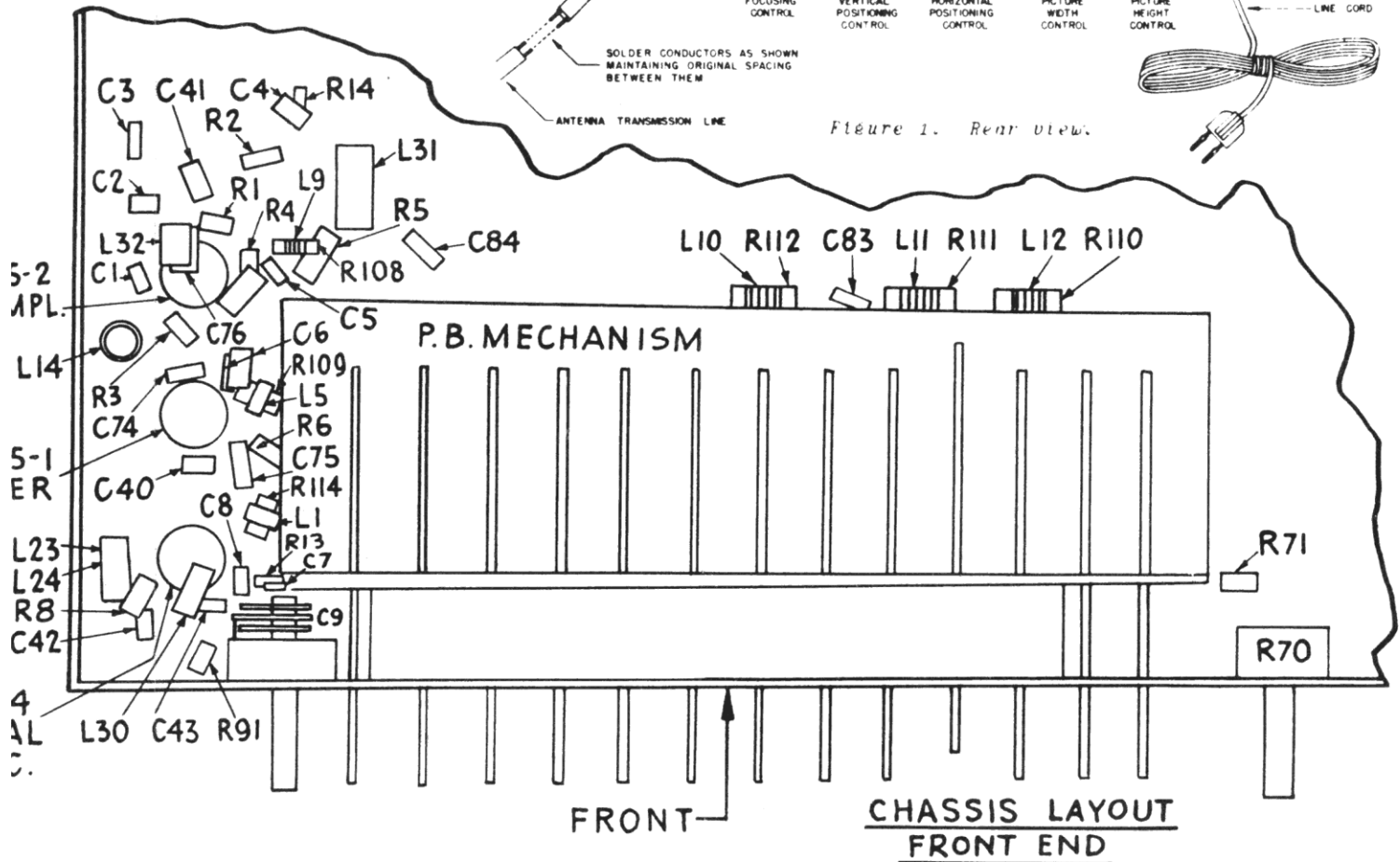
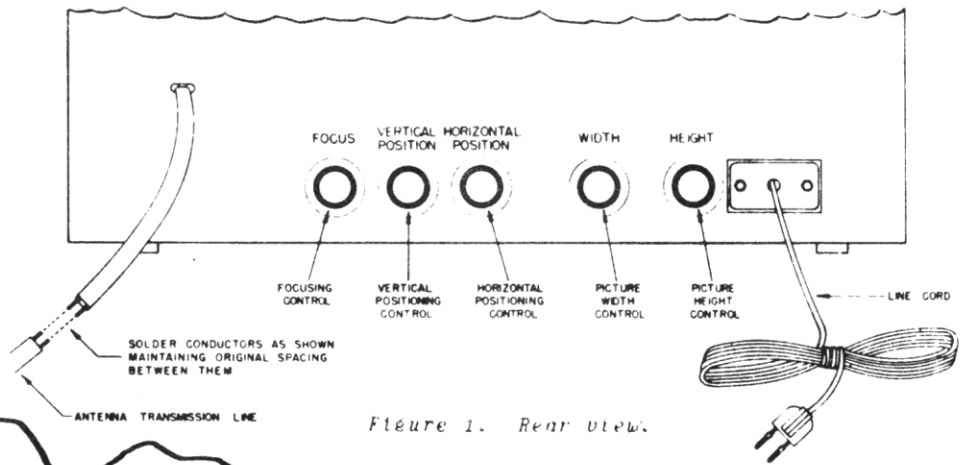
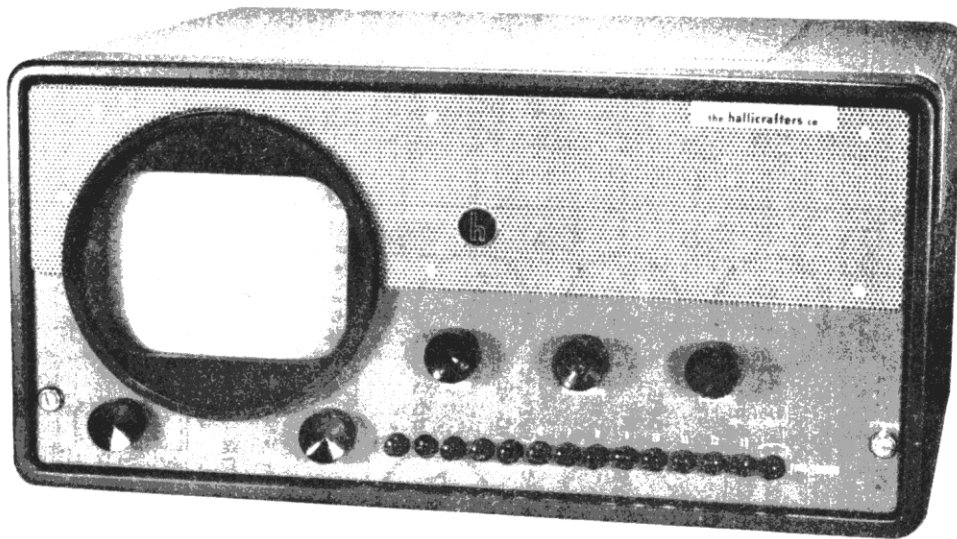

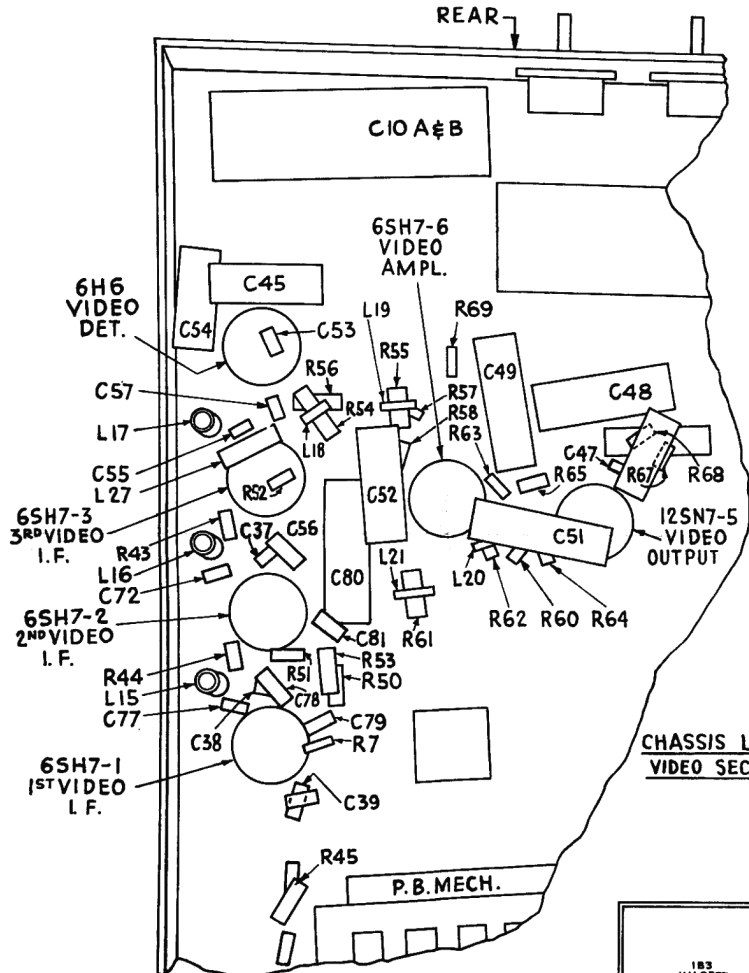
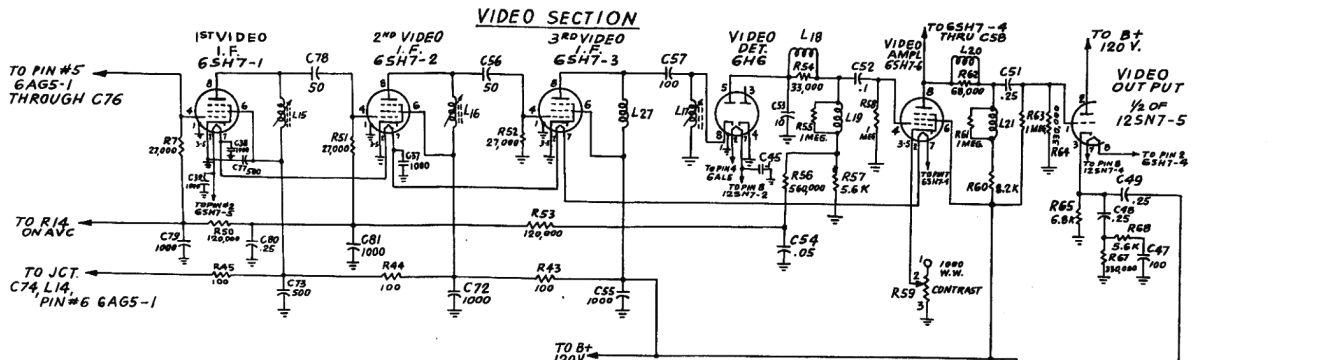

R59 SHOWN IN LOW VOLTAGE POWER SUPPLY LAYOUT

R70 AND R71 SHOWN ON FRONT END LAYOUT.

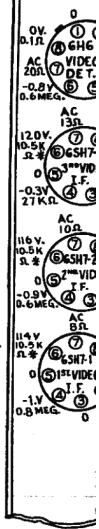

CHASSIS LAYOUT VIDEO SECTION

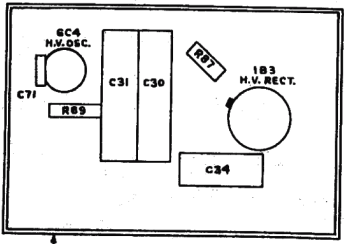
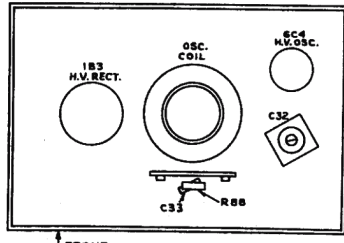

SCHMATIC H.V. POWER SUPPLY

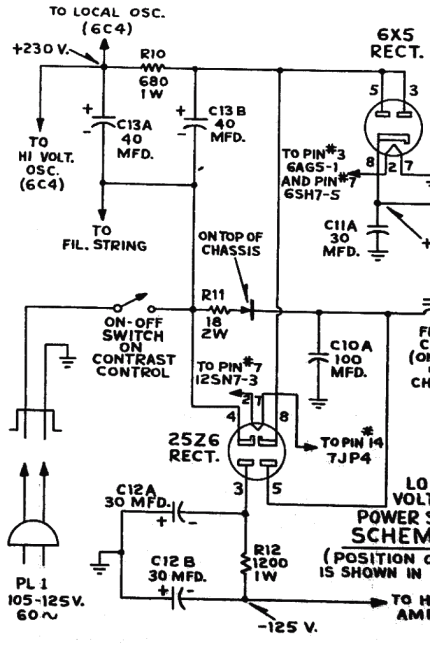
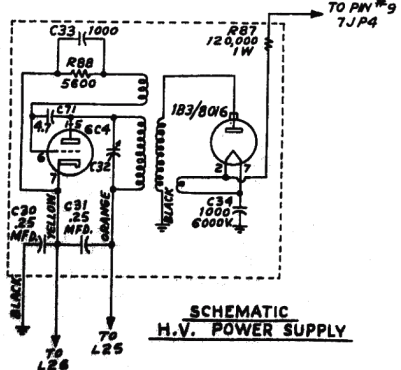

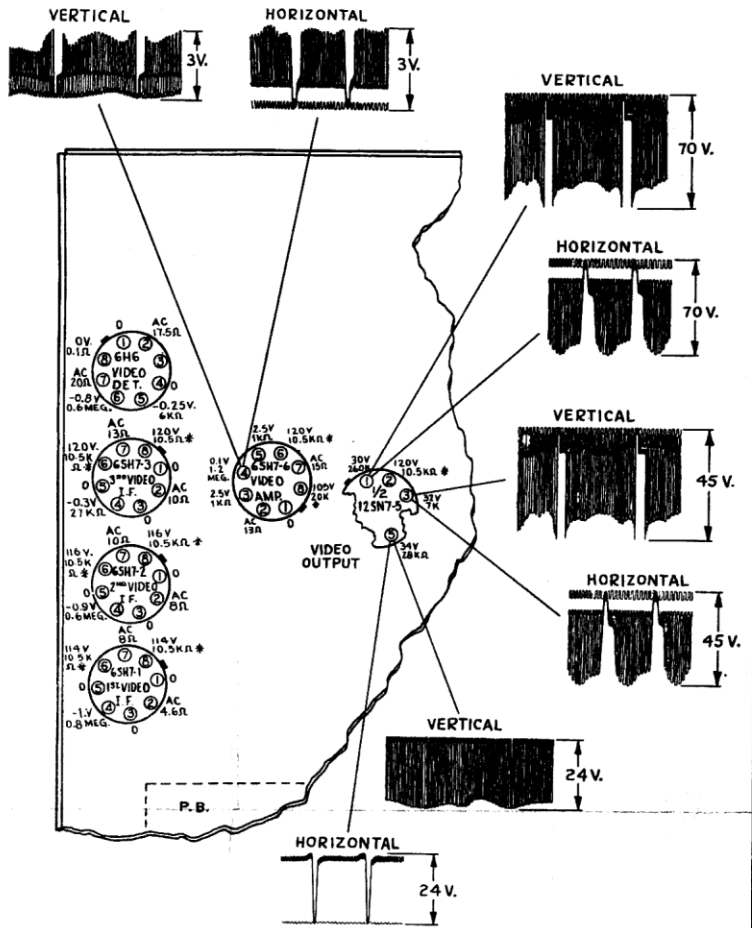
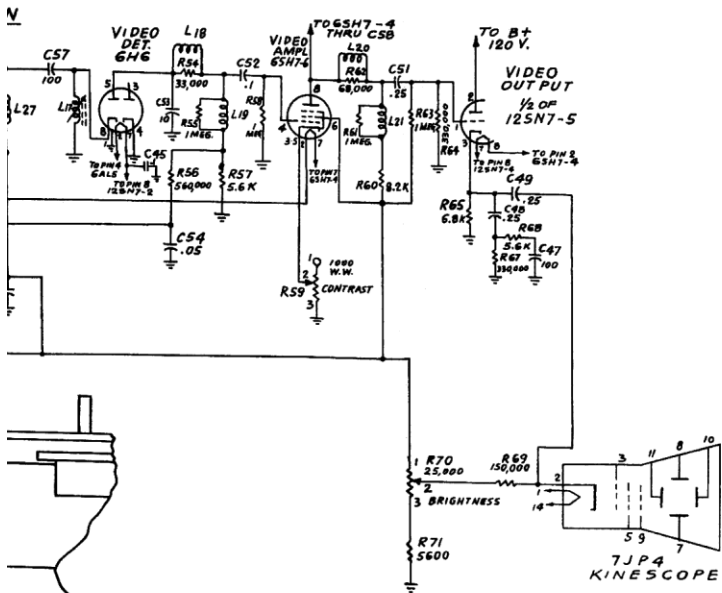

R59 SHOWN IN LOW VOLTAGE POWER SUPPLY LAYOUT

R70 AND R71 SHOWN ON FRONT END LAYOUT.

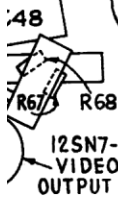

CHASSIS LAYOUT VIDEO SECTION

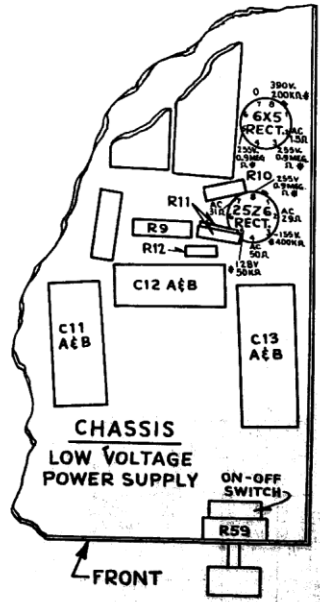
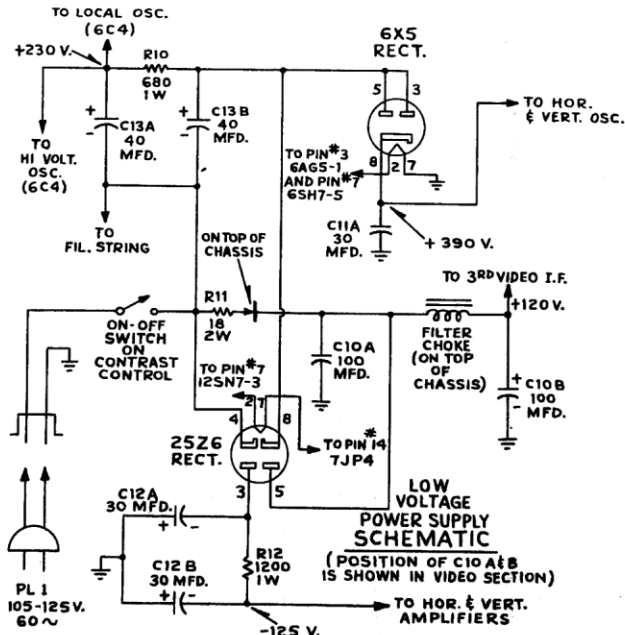
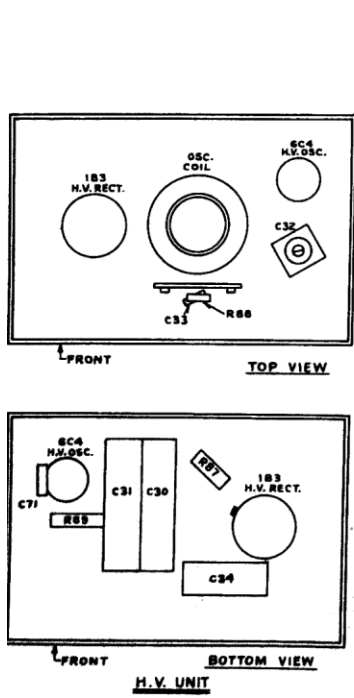

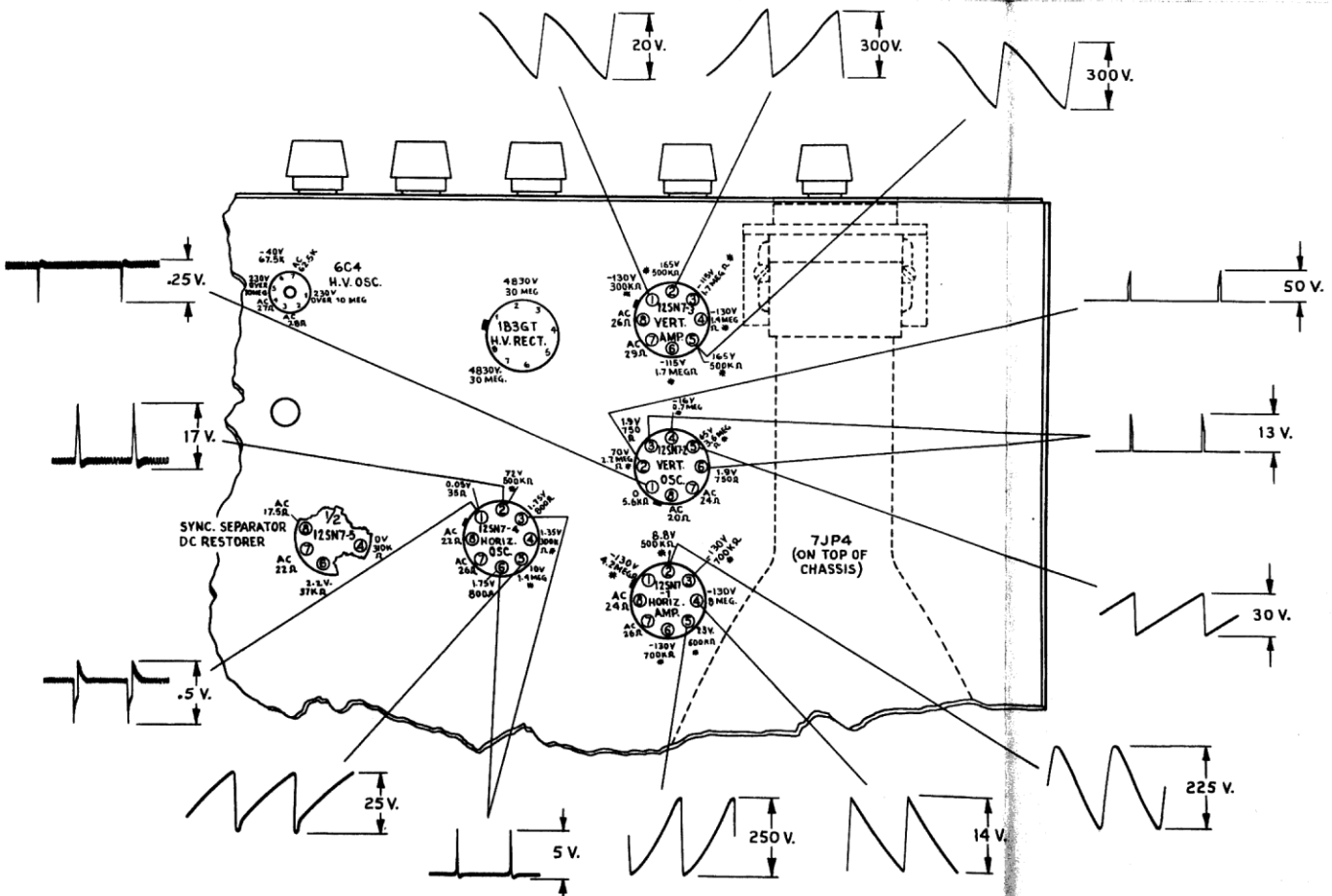
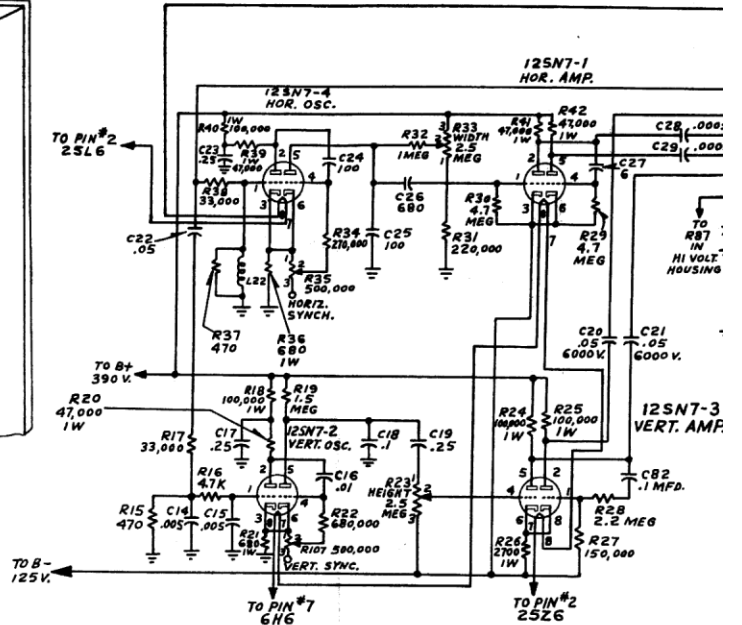
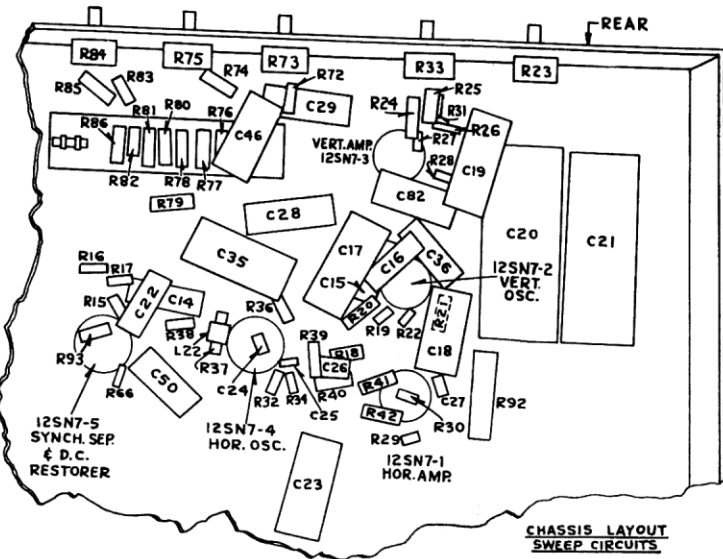

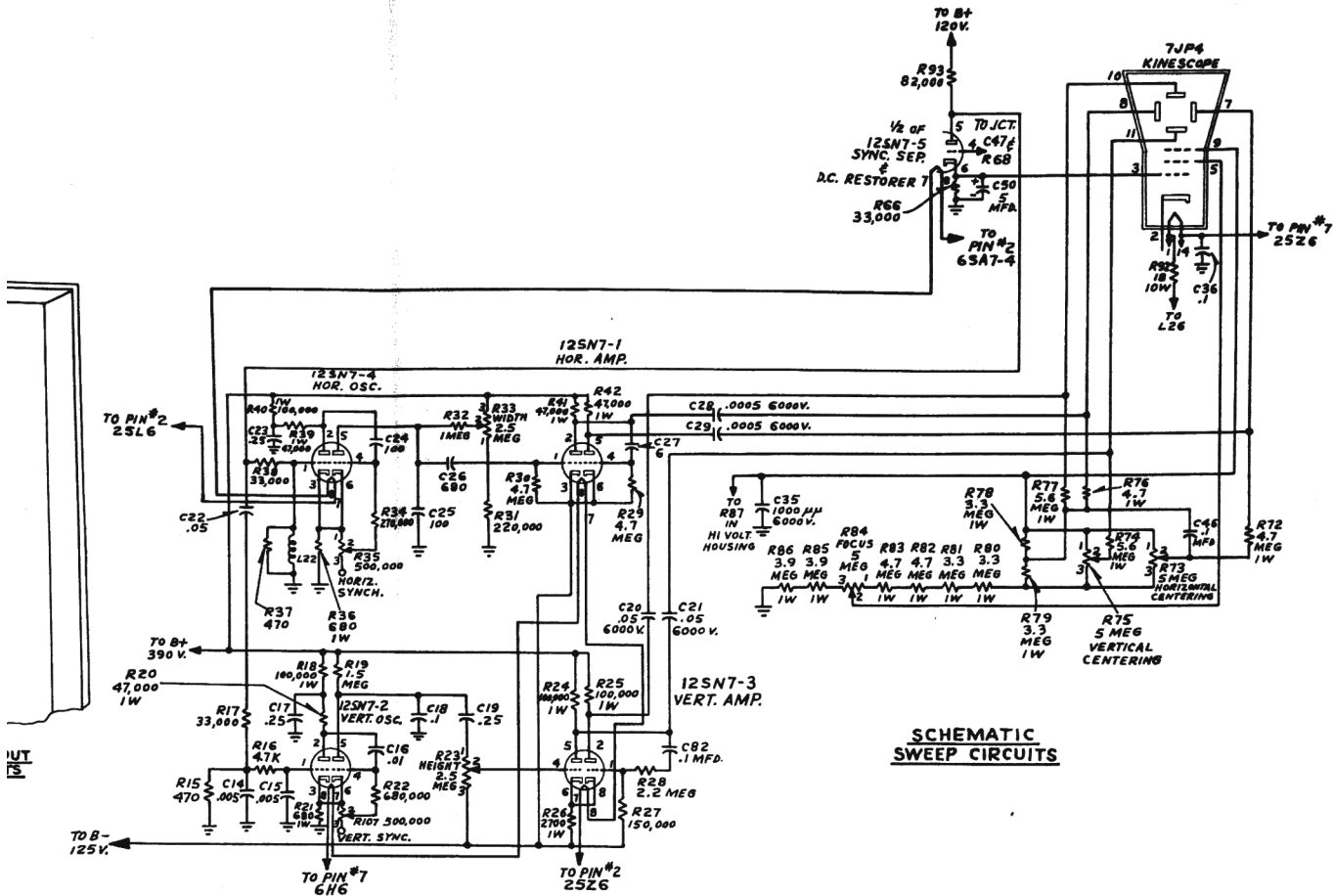

SCHEMATIC SWEEP CIRCUITS

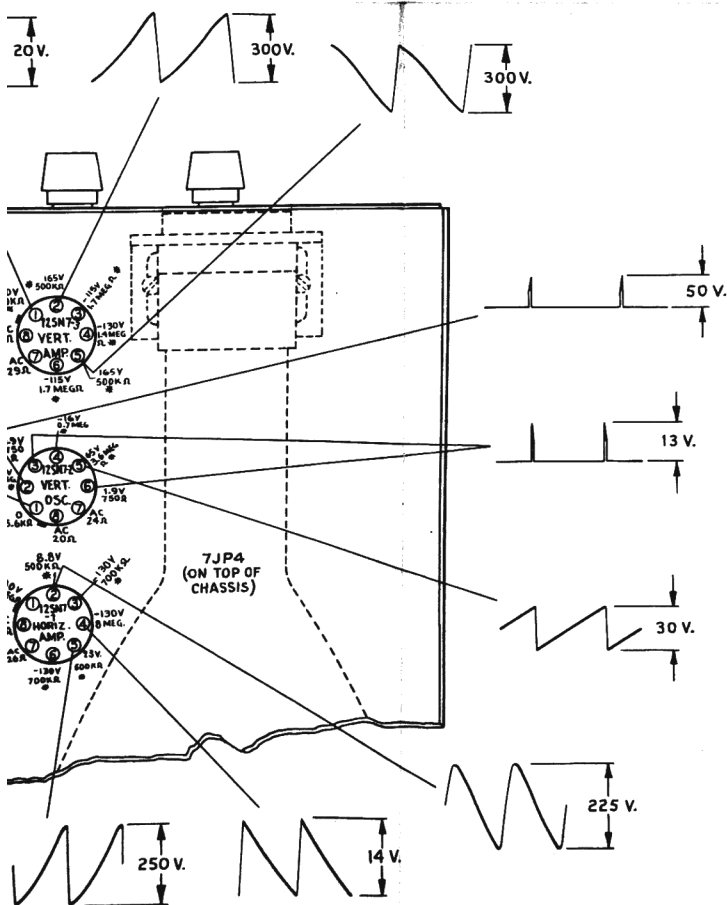

The waveforms shown were taken with an RCA 70-79A Oscilloscope. This oscilloscope has a wide-band vertical amplifier which is desirable when observing waveforms. An antenna was connected to the receiver, and the receiver was tuned to a station on the air at the time.

The voltages given for the different waveforms are those obtained when the input signal is sufficient to produce a 3 volt signal at the output of the video detector. All voltages given with reference to waveforms are peak-to-peak voltages. For several test-points, two waveforms are shown, one marked horizontal and the other vertical. These are the same signal, but the oscilloscope is adjusted so that either the horizontal or the vertical sync pulses can be observed. For the horizontal pattern, the oscilloscope sweep is set at half the frequency of the horizontal sync pulses (15,750 cps) and for the vertical pattern, the oscilloscope sweep is set at half the frequency of the vertical sync pulses (80 cps). This will produce two cycles of each pulse on the oscilloscope screen.

The background pattern observed on some of the waveforms is due to the picture content of the signal. This will change with the picture being transmitted at the time, and is not especially significant. As a rule, the sync pulses and sweep signals at the various points in the circuit will be more helpful in the servicing of a television receiver, than the picture signal.

TUBE	1	2	3	4	5	6	7	8	9	10	11	12	13	14
7JP4	AC	40 V	2.0 V	-	1820 V	-	4420 V	4420 V	4420 V	4160 V	4160 V	-	-	AC

VOLTAGES TAKEN WITH 20,000/V METER

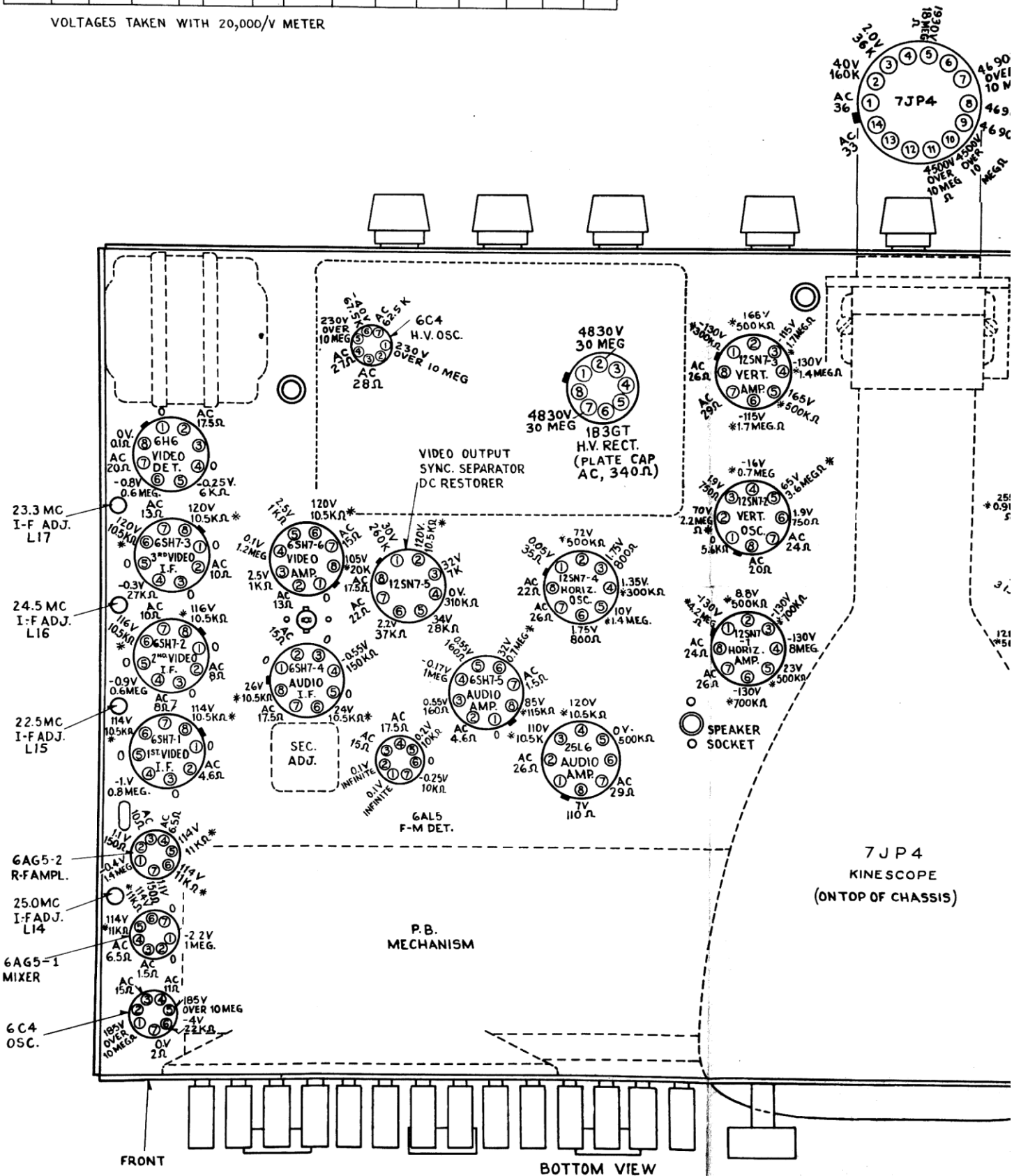

	11	12	13	14
V	4160 V	-	-	AC

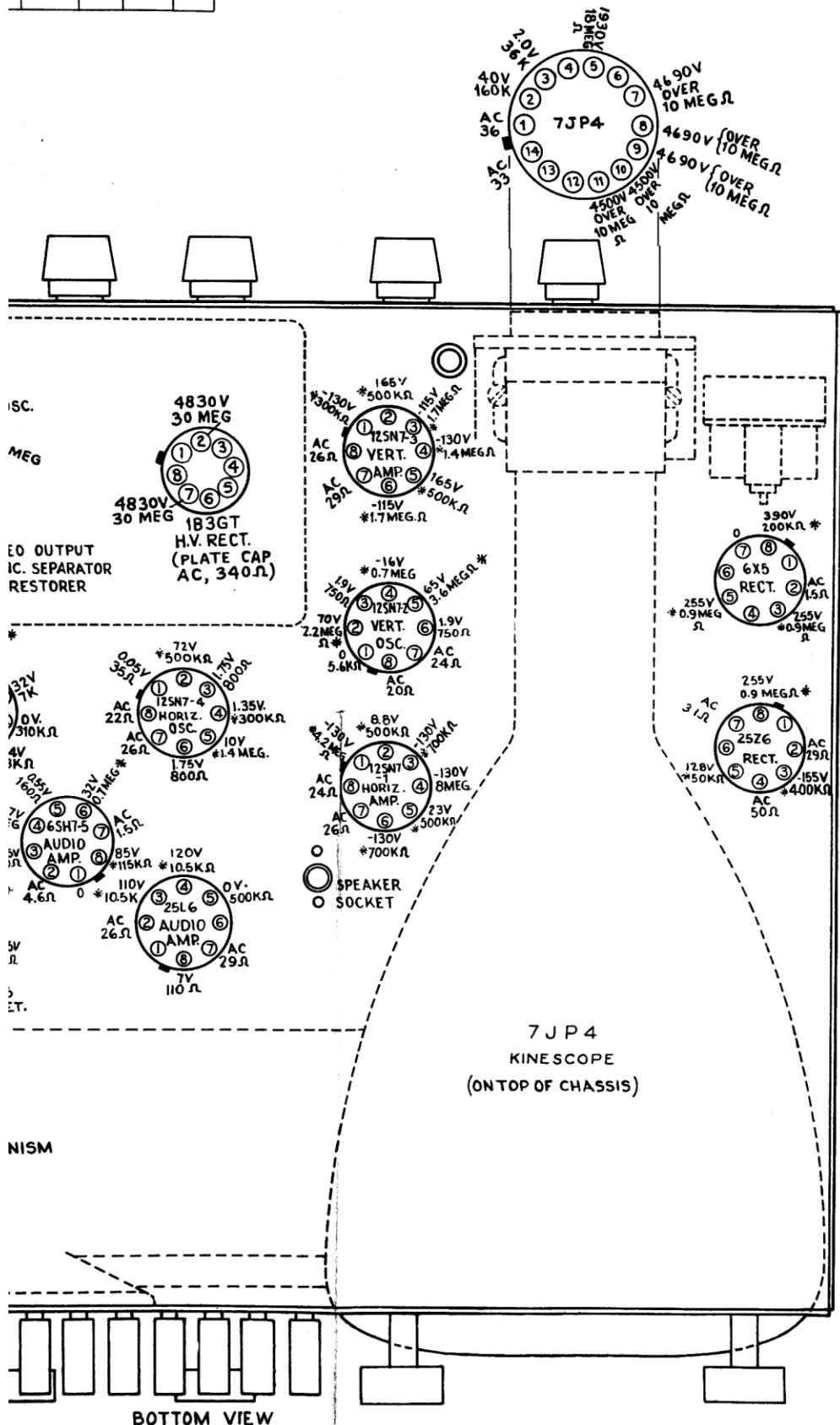

VOLTAGES SHOWN ON DRAWING ARE VTVM READINGS.

RESISTANCE MEASUREMENTS TAKEN WITH ALL CONTROLS IN THE MAXIMUM CLOCKWISE POSITION.

CHANNEL #3 PUSHBUTTON IS DEPRESSED.

* THESE VALUES MAY VARY DUE TO LEAKAGE OF THE ELECTROLYTIC CONDENSERS.

VOLTAGE MEASUREMENTS TAKEN WITH ALL CONTROLS TURNED MAX. CLOCKWISE EXCEPT CONTRAST CONTROL WHICH IS JUST TURNED TO "ON" POSITION.

CHANNEL #3 PUSHBUTTON IS DEPRESSED.

BLANK PINS SHOW NO CONNECTIONS.

ALL VOLTAGE AND RESISTANCE MEASUREMENTS MADE WITH RESPECT TO CHASSIS GROUND AND WITH A LINE VOLTAGE OF 117 VOLTS A.C.

VOLTAGES TAKEN WITH 20,000/V METER

TUBE	1	2	3	4	5	6	7	8
6AQ5 -2 RF AMP	0	1 V	AC	AC	114 V	114 V	1 V	
6AQ5 -1 MIXER	-0.6 V	0	AC	AC	114 V	114 V	0	0
6CA OSC	185 V	-	AC	AC	185 V	0	0	
6BT -1 1st VIDEO IF	0	AC	0	-3.6 V	0	114 V	AC	114 V
6BT -2 2nd VIDEO IF	0	AC	0	-0.2 V	0	116 V	AC	116 V
6BT -3 3rd VIDEO IF	0	AC	0	-0.2 V	0	120 V	AC	120 V
6IB VIDEO DET	0	AC	-	0	-2.2 V	-0.6 V	AC	U
6BT -4 VIDEO AMP	0	AC	2.5 V	0	2.5 V	122 V	AC	125 V
12BT -5 VIDEO OUTPUT SYNC. SEPARATOR DC RESTORER	30 V	120 V	32 V	0	34 V	2.0 V	AC	AC
6BT -4 AUDIO IF	0	AC	0	-0.32 V	0	24 V	AC	24 V
6AL5 AUDIO DET	0.1 V	0.1 V	AC	AC	3.2 V	0	-0.24	
6BT -5 AUDIO AMP	0	AC	0.55 V	-0.1 V	0.55 V	32 V	AC	35 V
25L6 AUDIO AMP	-	AC	110 V	120 V	0	-	AC	11 V
12BT -4 HORIZONTAL OSC	0	72 V	1.75 V	0.6 V	10 V	1.75 V	AC	AC
12BK -1 HORIZONTAL AMP	150 V	3.2 V	-150 V	-150 V	23 V	130 V	AC	AC
12BT -2 VERTICAL OSC	0	70 V	1.9 V	-16 V	65 V	1.9 V	AC	AC
12BT -3 VERTICAL AMP.	-130 V	165 V	-116 V	-130 V	1.2 V	-115 V	AC	AC
25Z6 RECTIFIER	-	AC	-155 V	AC	128 V	-	AC	258 V
6X5 RECTIFIER	-	AC	255 V	-	255 V	-	0	330 V
6CA HY OSC.	230 V	-	AC	AC	230 V	-40 V	AC	
185 HY RECTIFIER	-	4420 V	-	-	-	-	AC	4420 V

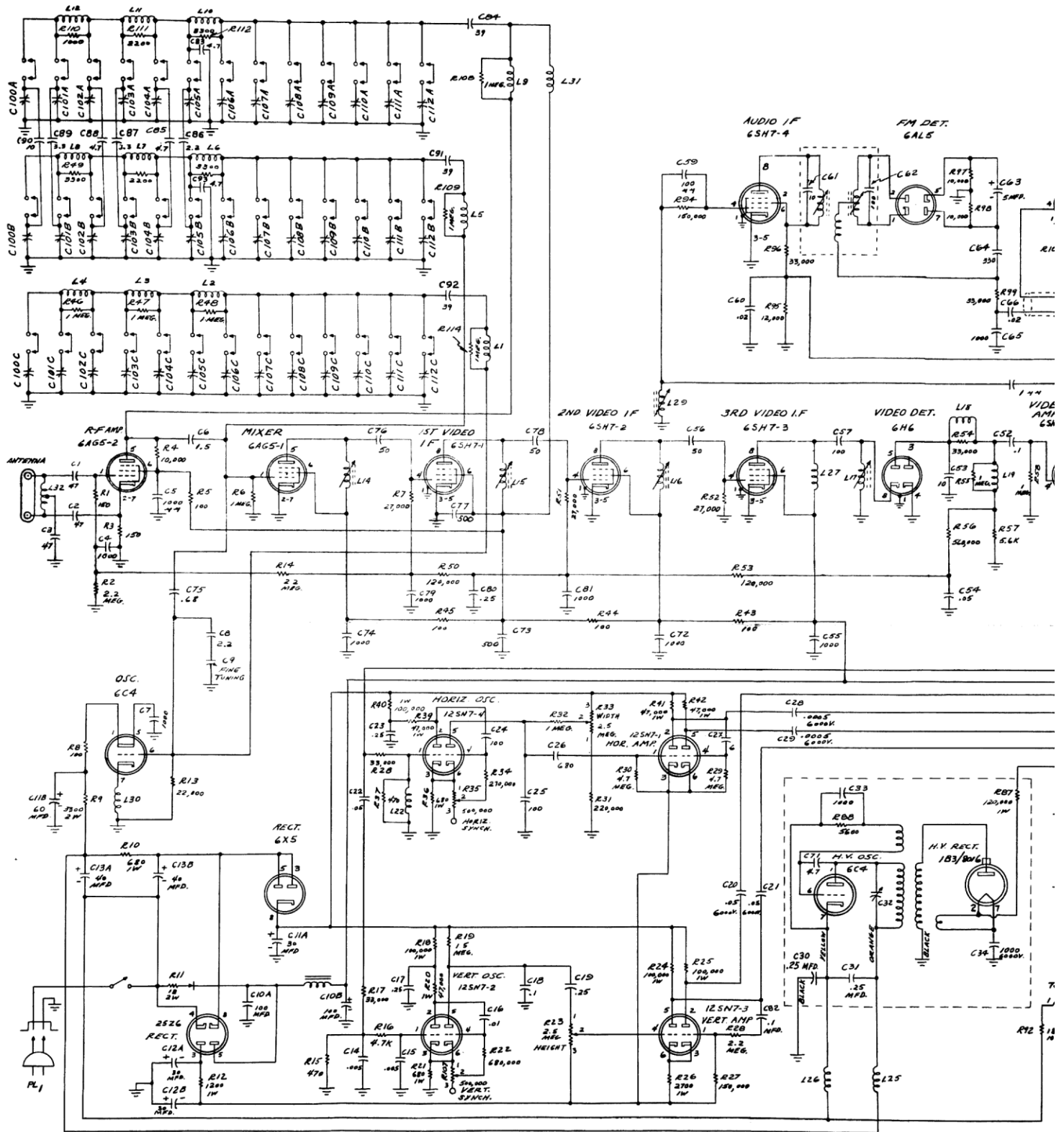

HIGH VOLTAGE WARNING

OPERATION OF THE RECEIVER OUTSIDE THE CABINET INVOLVES A SHOCK HAZARD. NORMAL OPERATION OF THE TELEVISION RECEIVER INSIDE ITS HOUSING IS PERFECTLY SAFE. INTERLOCKS ARE PROVIDED FOR YOUR PROTECTION, DO NOT TAMPER WITH THEIR MECHANISM.

KINESCOPE HANDLING PRECAUTIONS

THE KINESCOPE HOUSING PROVIDES ADEQUATE PROTECTION AGAINST POSSIBLE TUBE IMPLOSION WHILE IN THE CABINET. DO NOT OPEN THE KINESCOPE HOUSING OR HANDLE THE KINESCOPE TUBE IN ANY WAY WITHOUT PROVIDING PERSONAL PROTECTION IN THE FORM OF SHATTERPROOF GOGGLES AND HEAVY GLOVES. THE KINESCOPE TUBE SHOULD BE HANDLED BY QUALIFIED PERSONNEL ONLY.

are
the
high
cdu

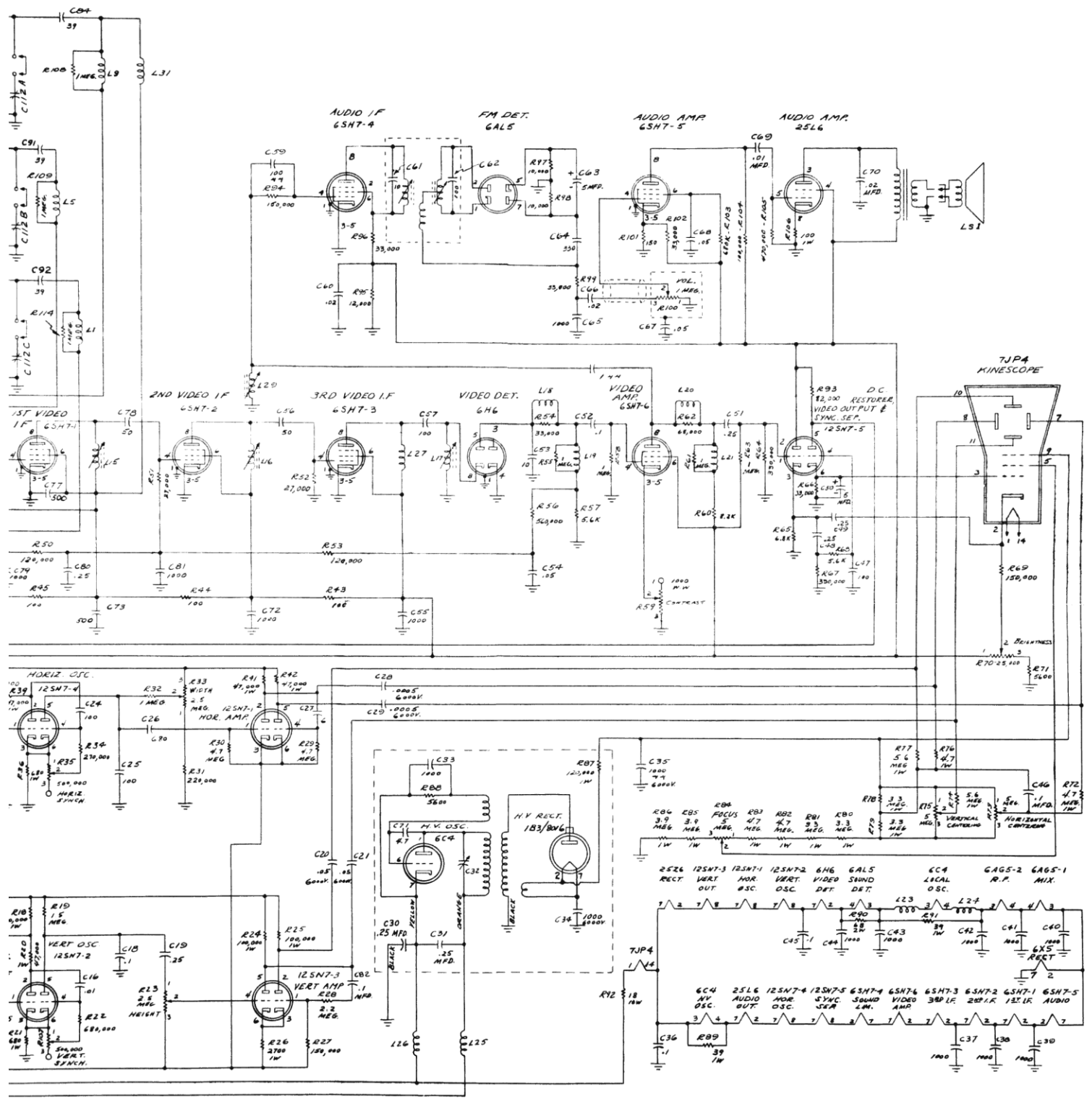

KINESCOPE HANDLING PRECAUTIONS

OCK HAZARD.
S PERFECTLY
R WITH THEIR

THE KINESCOPE HOUSING PROVIDES ADEQUATE PROTECTION AGAINST POSSIBLE TUBE IMPLOSION WHILE IN THE CABINET. DO NOT OPEN THE KINESCOPE HOUSING OR HANDLE THE KINESCOPE TUBE IN ANY WAY WITHOUT PROVIDING PERSONAL PROTECTION IN THE FORM OF SHATTERPROOF GOGGLES AND HEAVY GLOVES. THE KINESCOPE TUBE SHOULD BE HANDLED BY QUALIFIED PERSONNEL ONLY.

The kinescope envelope encloses a high vacuum and with the large surface area of glass involved, the stresses set up, particularly at the front rim of the tube, are considerable. An abnormal handling stress, accidental blow at a highly stressed surface, or even a scratch on the surface of the tube could cause it to implode or collapse with destructive violence.